

Tape & Reel Information for Plastic Encapsulated MMICs
(Applicable to SOT89, SOIC8, SOT363, DFN Packages)

SOT-89 Package

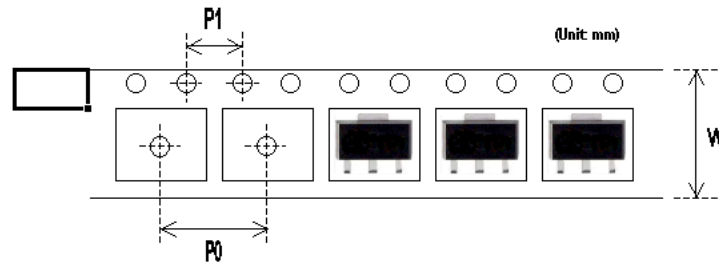

Package	Carrier Width (W)	Pitch (P0)	Pitch (P1)	Part per Reel	Reel Size
SOT-89	12 mm	8 mm	4 mm	1,000 pcs	180 mm

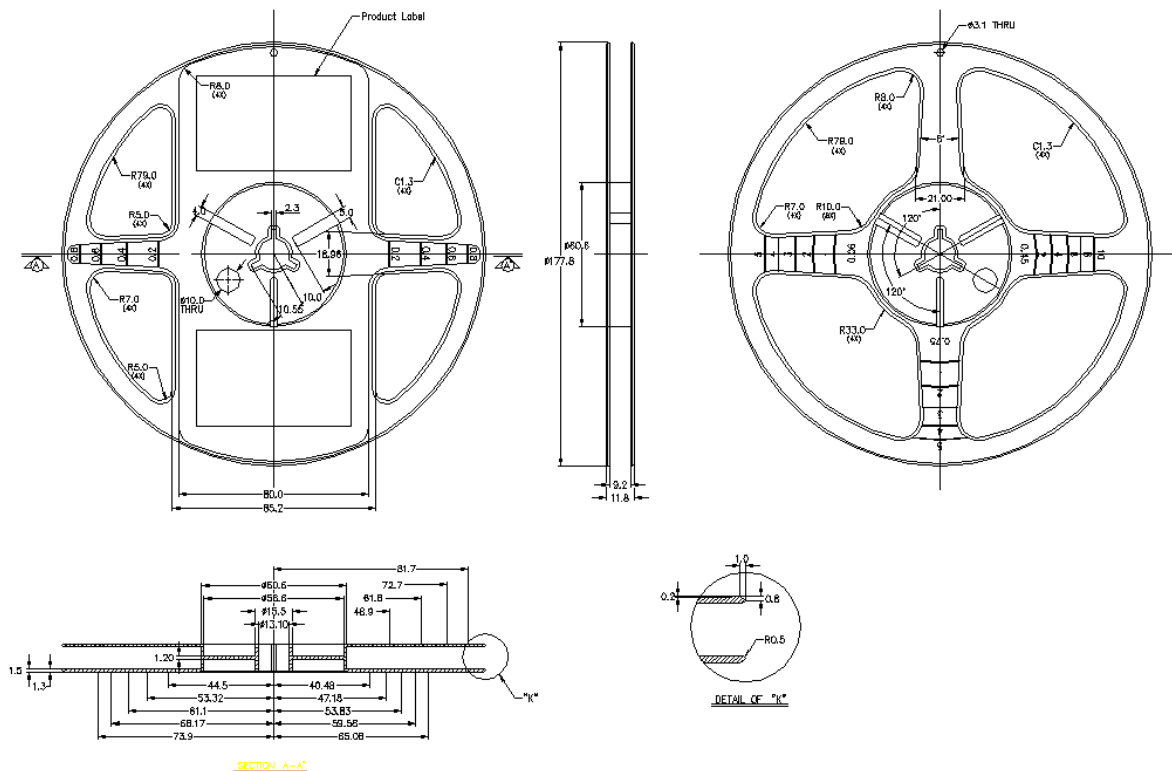

SOIC8 Package

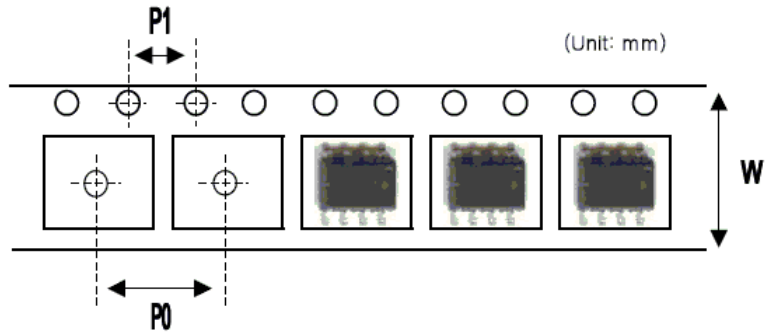

Package	Carrier Width (W)	Pitch (P0)	Pitch (P1)	Part Per Full Reel	Reel Size
SOIC-8	12 mm	8 mm	4 mm	1,000 pcs	180 mm

SOT363 Package

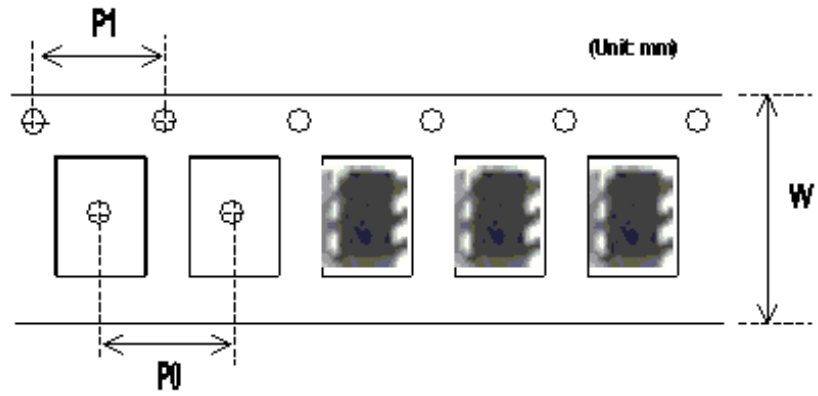

Package	Carrier Width (W)	Pitch (P0)	Pitch (P1)	Part Per Full Reel	Reel Size
SOT-363	8 mm	4 mm	4 mm	3,000 pcs	180 mm

DFN6 Package

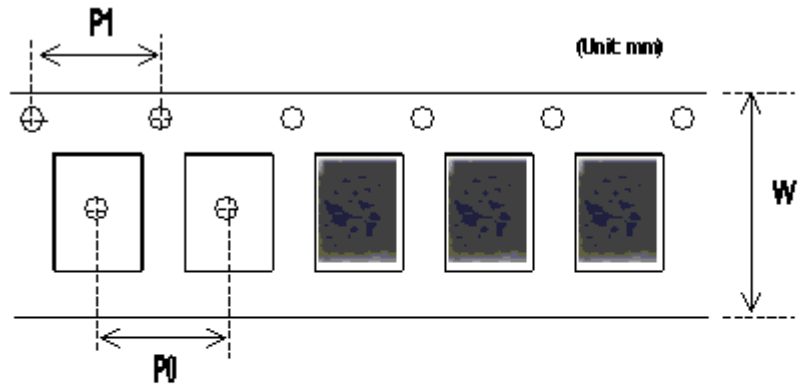

Package	Carrier Width (W)	Pitch (P0)	Pitch (P1)	Part Per Full Reel	Reel Size
DFN-6	12 mm	8 mm	4 mm	1,000 pcs	180 mm