

Features

- 13.5 dB Gain at 1575 MHz
- 1.1 dB NF at 1575 MHz
- One-stage LNA

Description

AST163 is a one-stage LNA for GPS, DMB, and satellite receiver low noise blocks. It has a low noise, high gain, and high linearity over a wide range of frequency up to 6 GHz. It is also suitable for use in the low noise amplifier block of the mobile wireless systems of T-DMB, CDMA, GSM, PCS, WCDMA, WiBro, WiMAX, and WLAN so on. The amplifier is available in an SOT-363 package and passes the stringent DC, RF, and reliability tests.

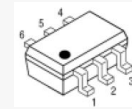

Package Style: SOT-363

Typical Performance

Parameters	Units	Typical			
		1575	1575	1575	1575
Testing Frequency	MHz	1575	1575	1575	1575
Gain	dB	13.5	14	15.5	14.2
S11	dB	-10	-12	-10	-10
S22	dB	-10	-14	-11	-10
Output IP3 ¹⁾	dBm	16	18	24	21.2
Noise Figure	dB	1.1	0.95	0.9	1.3
Output P1dB	dBm	10	10	10	10
Current	mA	3.7	6.0	9.5	9.5
Device Voltage	V	3	3	2.8	2.8

1) OIP3 is measured with two tones at an output power of -5dBm/tone separated by 1MHz.

Product Specifications*

Parameters	Units	Min	Typ	Max
Frequency	MHz		1575	
Gain	dB	13	13.5	
S11	dB		-10	
S22	dB		-10	
Output IP3	dBm	15	16	
Noise Figure	dB		1.1	1.3
Output P1dB	dBm	9	10	
Current	mA		3.7	
Device Voltage	V		3	

*100% in-house DC & RF testing is done on packaged products before taping

Absolute Maximum Ratings

Parameters	Rating
Operating Case Temperature	-40 to +85°C
Storage Temperature	-40 to +150°C
Device Voltage	+5 V
Operating Junction Temperature	+150°C
Input RF Power (CW, 50ohm matched)*	22 dBm

* Please find the max. input power data from http://www.asb.co.kr/pdf/Maximum_Input_Power_Analysis.pdf

Application Circuit

- GPS
- GPS (2.8 V)
- GPS (2.8 V / Without strip lines)
- 1710 ~ 1880 MHz
- 1950 MHz

Pin Configuration

Pin No.	Function
1	RF IN
2	GND
3	GND
4	RF OUT / Bias
5	GND
6	GND

Outline Drawing

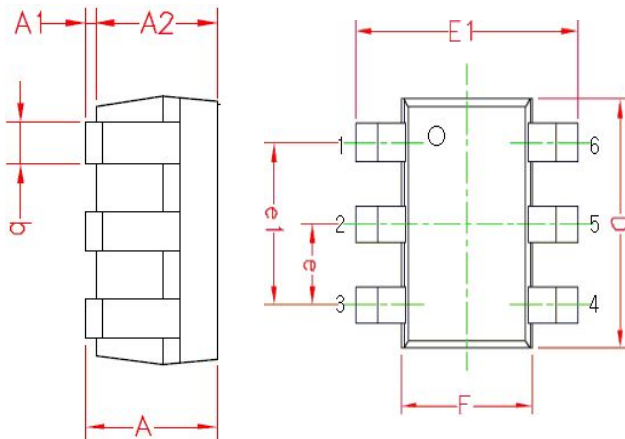

Symbols	Dimensions (In mm)		
	MIN	NOM	MAX
A	0.90	1.00	1.10
A1	0.025	0.062	0.10
A2	0.875	0.937	1.00
b	0.20	0.30	0.40
C	0.10	0.125	0.15
D	1.90	2.00	2.10
F	1.15	1.25	1.35
E1	2.00	2.10	2.20
e	--	0.65BSC	--
e1	--	1.30BSC	--
L	--	0.425REF	--

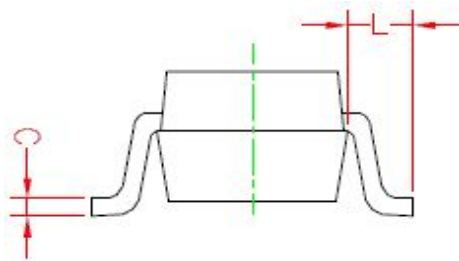

Pin NO.	Function	Pin NO.	Function.
1	RF IN	4	RF OUT / Bias
2	GND	5	GND
3	GND	6	GND

Ordering Information

Part Number	Description
-------------	-------------

APPLICATION CIRCUIT

GPS

1575 MHz

+3 V

Frequency (MHz)	1575	1575 ²⁾
Magnitude S21 (dB)	13.5	14
Magnitude S11 (dB)	-10	-12
Magnitude S22 (dB)	-10	-14
Output P1dB (dBm)	10	10
Output IP3 ¹⁾ (dBm)	16	18
Noise Figure (dB)	1.1	0.95
Supply Voltage (V)	3	3
Current (mA)	3.7	6.0

1) OIP3 is measured with two tones at an output power of -5 dBm/tone separated by 1MHz.

2) It is the test result when the R1 value is 1.1 kohm. A user can easily increase an operating current by choosing R1 value.

Schematic

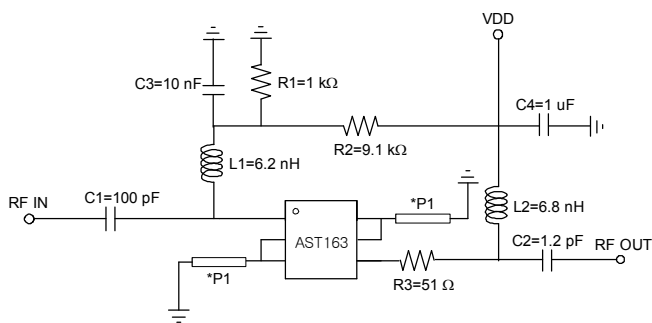

Note: 1) the length of the strip line P1 is given as below at the PCB with $\epsilon_r = 4.5$ and $T = 0.8$ mm.

*P1 Length: 3.5 mm, Width: 0.3 mm

2) Gain and S11 are in trade-off and varied with the length of P1

Board Layout (FR4, 15.3x12 mm², 0.8T)

Top

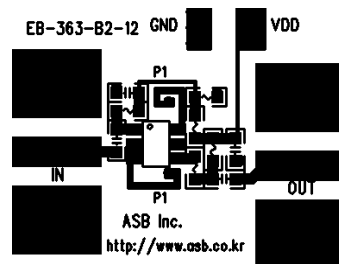

Bottom

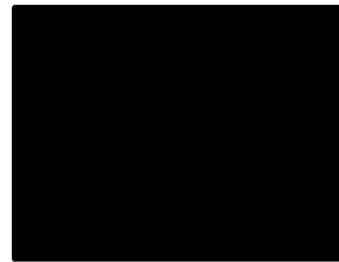

S-parameters & Noise Figure

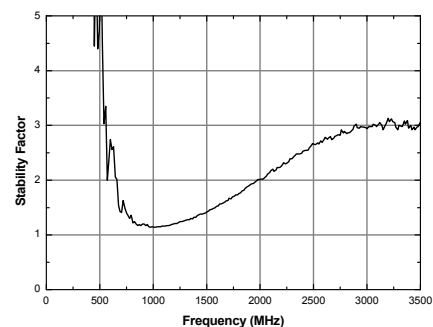
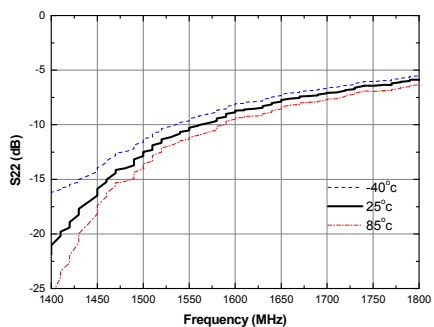
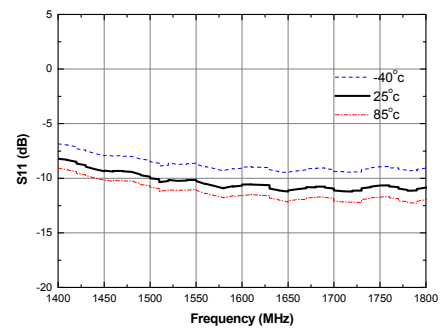
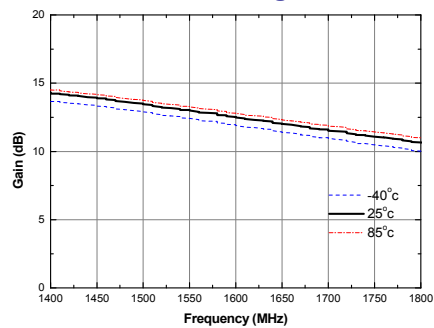

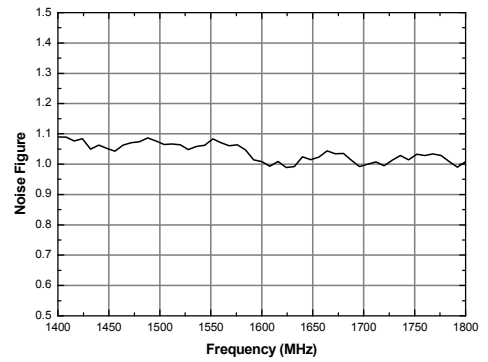
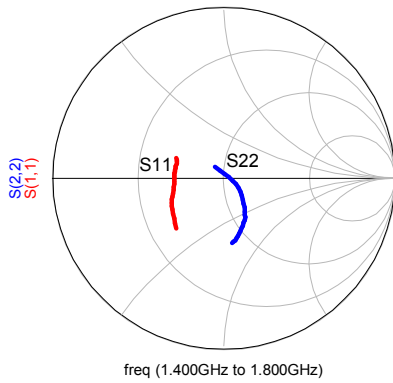

Current vs. Temperature

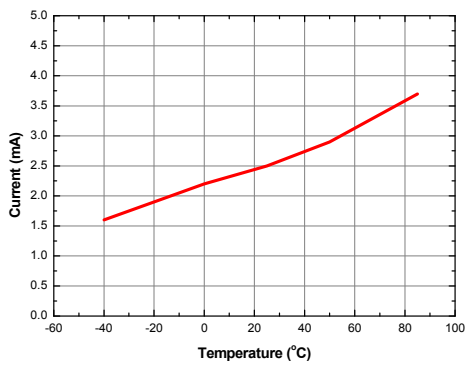

Gain vs. Temperature

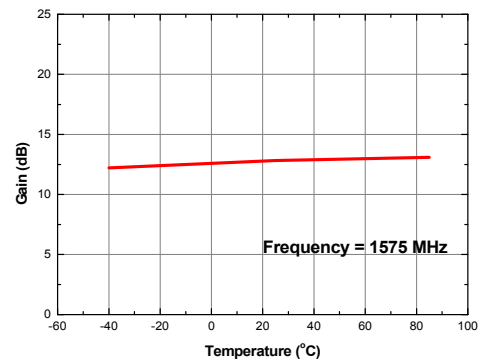

P1dB vs. Temperature

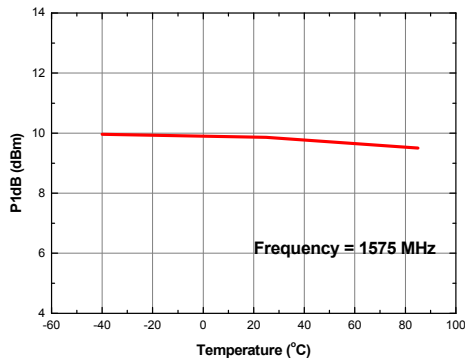

Output IP3 vs. Tone Power (Frequency = 1575 MHz)

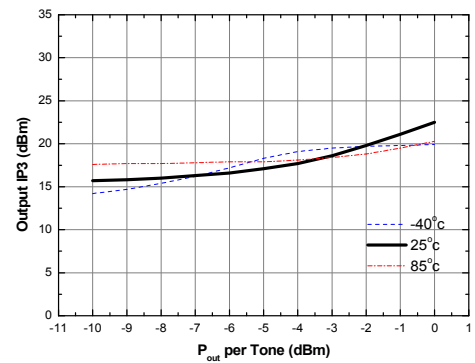

APPLICATION CIRCUIT

GPS

1575 MHz

+2.8 V

Frequency (MHz)	1575
Magnitude S21 (dB)	15.5
Magnitude S11 (dB)	-10
Magnitude S22 (dB)	-11
Output P1dB (dBm)	10
Output IP3 ¹⁾ (dBm)	24
Noise Figure (dB)	0.9
Supply Voltage (V)	2.8
Current (mA)	9.5

1) OIP3 is measured with two tones at an output power of -5 dBm/tone separated by 1MHz.

Schematic

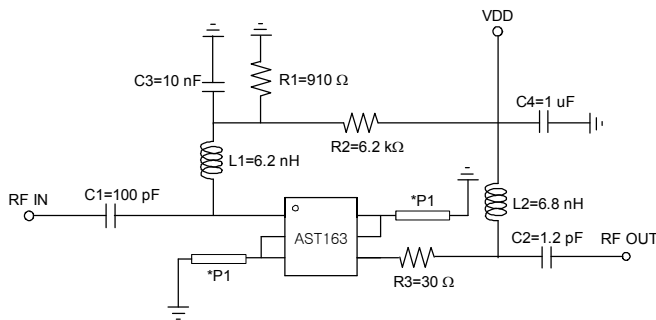

Note: 1) the length of the strip line P1 is given as below at the PCB with $\epsilon_r = 4.5$ and $T = 0.8$ mm.

*P1 Length: 3.4 mm, Width: 0.3 mm

2) Gain and S11 are in trade-off and varied with the length of P1

Board Layout (FR4, 15.3x12 mm², 0.8T)

Top

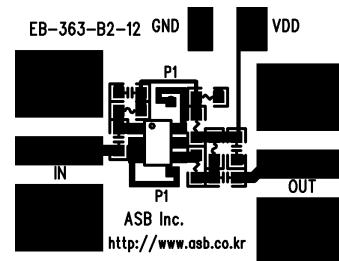

Bottom

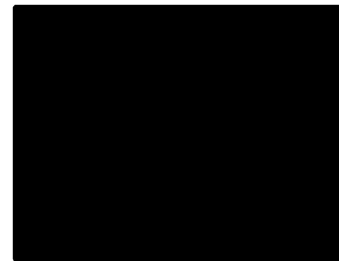

S-parameters & Noise Figure

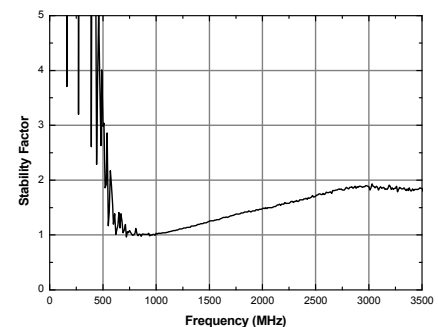
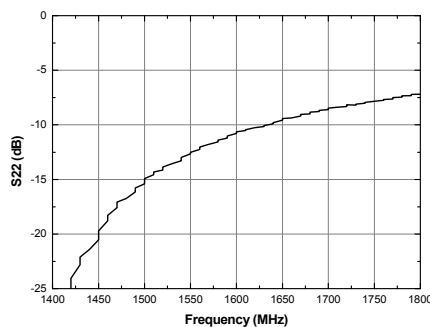
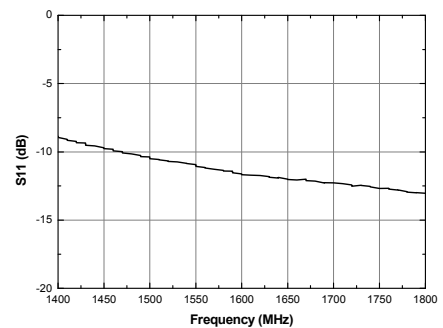
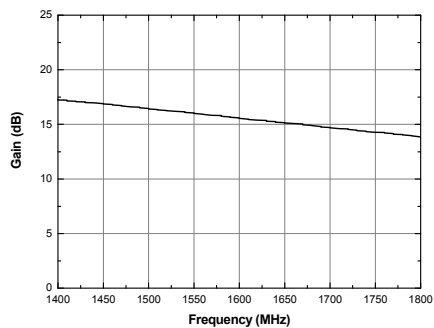

APPLICATION CIRCUIT

Without strip lines

GPS

1575 MHz

+2.8 V

Frequency (MHz)	1575
Magnitude S21 (dB)	14.2
Magnitude S11 (dB)	-10
Magnitude S22 (dB)	-10
Output P1dB (dBm)	10
Output IP3 ¹⁾ (dBm)	21.2
Input IP3 (dBm)	7
Noise Figure (dB)	1.3
Supply Voltage (V)	2.8
Current (mA)	9.5

1) OIP3 is measured with two tones at an output power of -5 dBm/tone separated by 1MHz.

Schematic

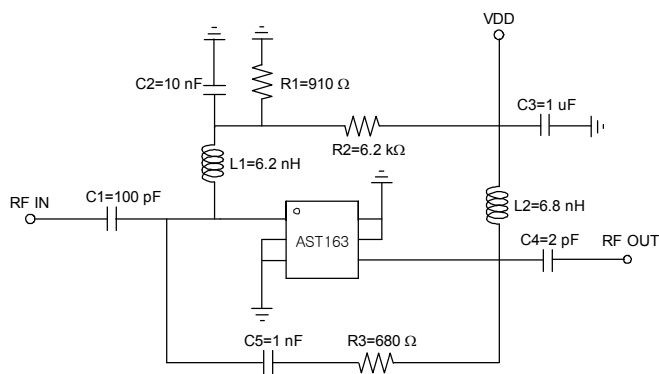

Board Layout (FR4, 15.3x12 mm², 0.8T)

Top

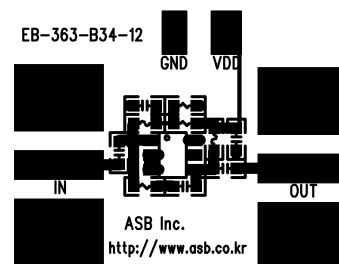

Bottom

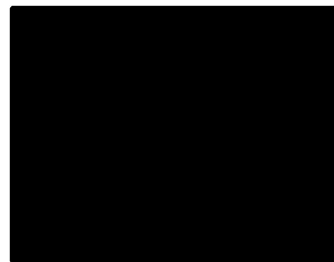

S-parameters & Noise Figure

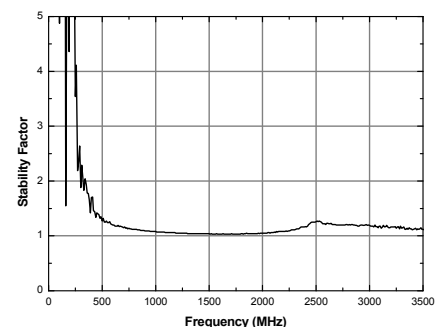
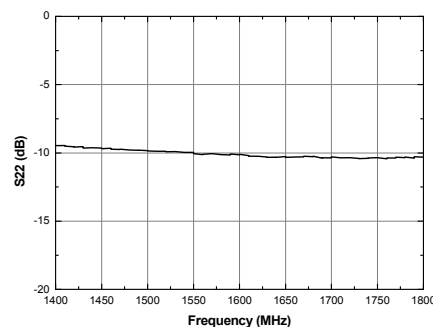
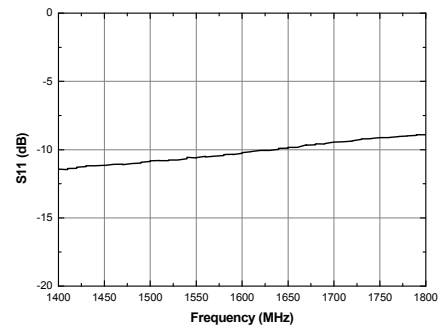
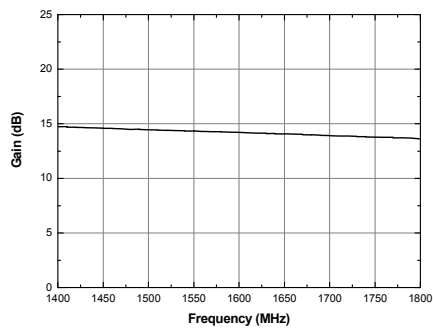

APPLICATION CIRCUIT

1710 ~ 1880 MHz

+5 V / 35 mA

Parameter	Symbol	Unit	Frequency [MHz]
			1710~1880
Power Gain	G_p	dB	17.5
Noise Figure	NF	dB	0.65
Input Return Loss	RL_{in}	dB	-10
Output Return Loss	RL_{out}	dB	-8
1 dB Gain Compression Output Power	$P_{o(1dB)}$	dBm	16.5
3 rd Intercept Point Output Power ¹⁾	OIP3	dBm	28
Circuit Current	I_{cc}	mA	35

1) OIP3 is measured with two tones at an output power of +0 dBm/tone separated by 1MHz.

Schematic

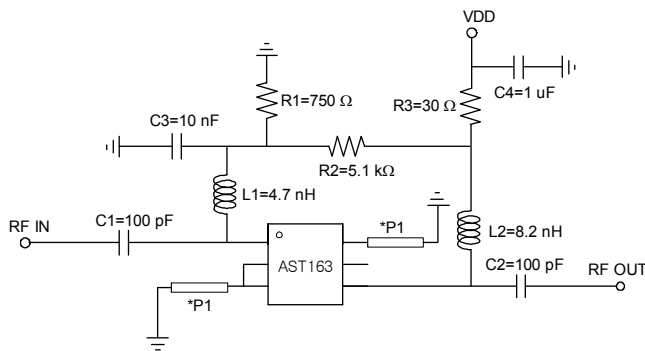

Note: 1) the length of the strip line P1 is given as below at the PCB with $\epsilon_r = 4.5$ and $T = 0.8$ mm.

*P1 Length: 0.4 mm, Width: 0.3 mm

2) Gain and S11 are in trade-off and varied with the length of P1

Board Layout (FR4, 23x13 mm², 0.8T)

Top

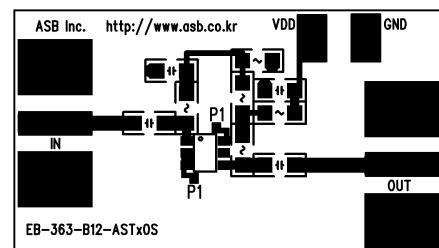

Bottom

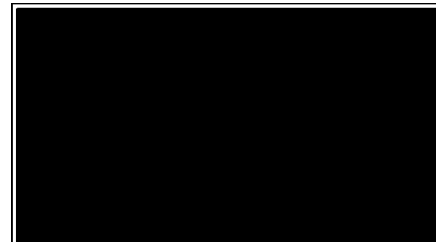

S-parameters & K-factor

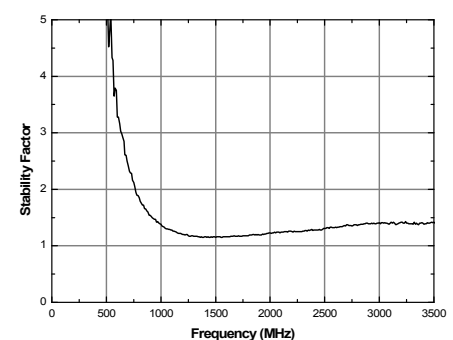
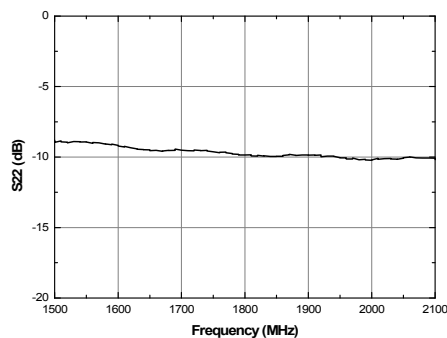
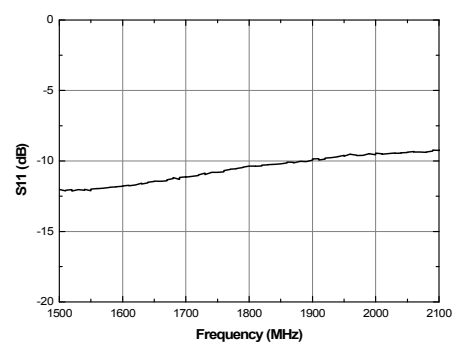
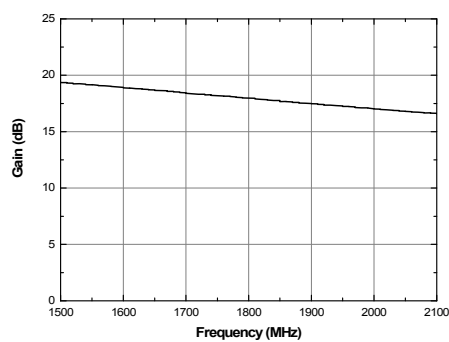

APPLICATION CIRCUIT

1950 MHz

+5 V / 25 mA

Parameter	Symbol	Unit	Frequency [MHz]
			1950
Power Gain	G_p	dB	16
Noise Figure	NF	dB	0.65
Input Return Loss	RL_{in}	dB	-10
Output Return Loss	RL_{out}	dB	-14
1 dB Gain Compression Output Power	$P_{o(1dB)}$	dBm	16
3 rd Intercept Point Output Power ¹⁾	OIP3	dBm	29
Circuit Current	I_{cc}	mA	25

1) OIP3 is measured with two tones at an output power of +0 dBm/tone separated by 1MHz.

Schematic

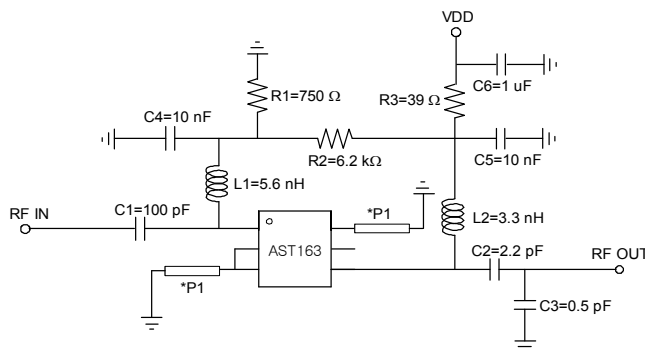

Note: 1) the length of the strip line P1 is given as below at the PCB with $\epsilon_r = 4.5$ and $T = 0.8$ mm.

*P1 Length: 1.2 mm, Width: 0.3 mm

2) Gain and S11 are in trade-off and varied with the length of P1

Board Layout (FR4, 23x13 mm², 0.8T)

Top

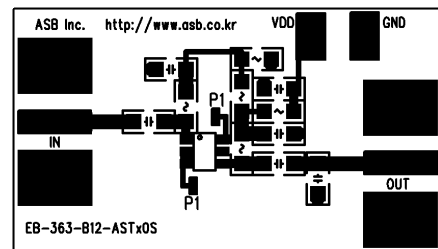

Bottom



S-parameters & K-factor

