

### Features

- 17.9 dB Gain at 500 Mz
- 25 dBm P1dB at 500 MHz
- 42.5 dBm Output IP3 at 500 MHz
- 1.5 dB NF at 500 MHz
- 75 Ω Input & Output Match
- Bandwidth 5 ~ 1200 MHz
- Single Supply

### Description

The ASL560, a wideband linear amplifier MMIC, has a high linearity and low noise over a wide range of frequency 5 MHz to 2.6 GHz, being suitable for use in the fiber receiver, distribution amplifiers and drop amplifiers of CATV systems, and in the mobile wireless repeaters and BTS. The amplifier is available in a SOT89 package and passes through the stringent DC, RF, and reliability tests.



Package Style: SOT89

### Typical Performance

(Supply Voltage = +8 V, T<sub>A</sub> = +25 °C, Z<sub>0</sub> = 75 Ω)

Parameters	Units	Typical						
		5	50	500	860	1200	1500	
Frequency	MHz	5	50	500	860	1200	1500	
Noise Figure	dB	2.1	1.4	1.5	1.6	1.9	2.0	
Gain	dB	18.0	17.8	17.9	17.6	16.2	17.1	
S11	dB	-11	-13	-14	-12	-12	-7	
S22	dB	-10	-17	-16	-17	-12	-11	
Output P1dB	dBm	24.0	24.5	25.0	23.5	23.5	20.5	
Output IP3 <sup>1)</sup>	dBm	40.0	43.0	42.5	36.5	39.0	40.0	
Output IP2 <sup>1),2)</sup>	dBm	53	54	52	66	51	52	
CSO <sup>3)</sup>	dBc	60						
CTB <sup>3)</sup>	dBc	75						
Current	mA	120						
Device Voltage	V	+8						

1) OIP3 and OIP2 are measured with two tones at an output power of +10 dBm/tone separated by 1 MHz (up-link) or 6 MHz (down-link).

2) OIP2 is measured at F1+F2 Frequency.

3) 60 channels, +36 dBμV per channel (measured at output).

### Product Specifications

Parameters	Units	Min	Typ.	Max
Testing Frequency	MHz		500	
Gain	dB	17.0	17.9	
S11	dB	-12	-14	
S22	dB	-14	-16	
Output IP3	dBm	39.0	42.5	
Noise Figure	dB		1.5	1.8
Output P1dB	dBm	24	25	
Current	mA	100	120	142
Device Voltage	V		+8	

### Absolute Maximum Ratings, T<sub>A</sub> = +25 °C

Parameters	Rating
Operating Case Temperature	-40 to +85 °C
Storage Temperature	-40 to +150 °C
Device Voltage	+9V
Operating Junction Temperature	+150°C
Input RF Power (CW, 75 Ω matched)*	+4 dBm
Maximum Current	220 mA
Thermal Resistance	43 °C/W

The operation of this device in excess of any of these limits may cause permanent damage.

\* Refer to the max. input power data at [http://www.asb.co.kr/pdf/Maximum\\_Input\\_Power\\_Analysis.pdf](http://www.asb.co.kr/pdf/Maximum_Input_Power_Analysis.pdf). The max. input power, in principle, depends upon the application frequency, the matching circuit, and device voltage.

### Application Circuit

- 50 ~ 1000 MHz
- 50 ~ 1200 MHz
- 5 ~ 200 MHz
- 950 ~ 1500 MHz  
(SMATV & EOC)
- 800 ~ 2500 MHz
- 50 ~ 1000 MHz  
(Push-Pull, 1:1 transformer)
- 50 ~ 1200 MHz  
(Push-Pull, 1:1 transformer)
- 5 ~ 200 MHz  
(Push-Pull, 1:1 transformer)

### Pin Configuration

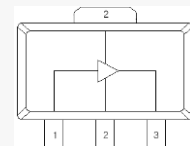

Pin No.	Function
1	RF IN
2	GND
3	RF OUT & Bias



### APPLICATION CIRCUIT

CATV

50 ~ 1000 MHz

+8 V

Frequency (MHz)	50	500	860
Noise Figure (dB)	1.4	1.5	1.6
Magnitude S21 (dB)	17.8	17.9	17.6
Magnitude S11 (dB)	-13	-14	-12
Magnitude S22 (dB)	-17	-16	-17
Output P1dB (dBm)	24.5	25.0	23.5
Output IP3 <sup>1)</sup> (dBm)	43.0	42.5	36.5
Output IP2 <sup>1),2)</sup> (dBm)	54	52	66
CSO <sup>3)</sup> (dBc)	60		
CTB <sup>3)</sup> (dBc)	75		
Device Voltage (V)	+8		
Current (mA)	120		

1) OIP3 and OIP2 are measured with two tones at an output power of +10 dBm/tone separated by 6 MHz.

2) OIP2 is measured at F1+F2 Frequency.

3) 60 channels, +36 dBmV per channel (measured at output).

### Schematic

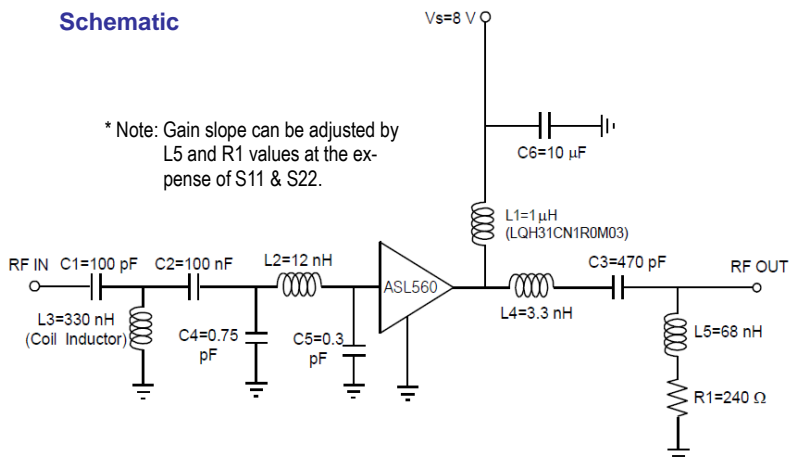

### Board Layout (FR4, 40x40 mm<sup>2</sup>, 0.8T)

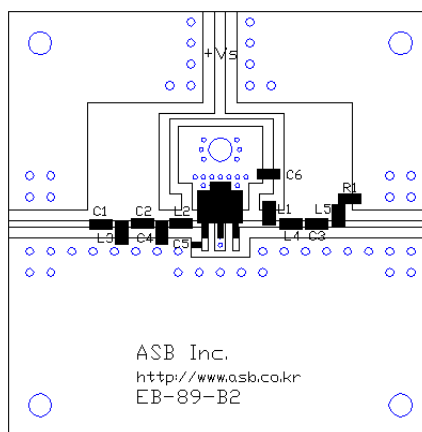

### S-parameters

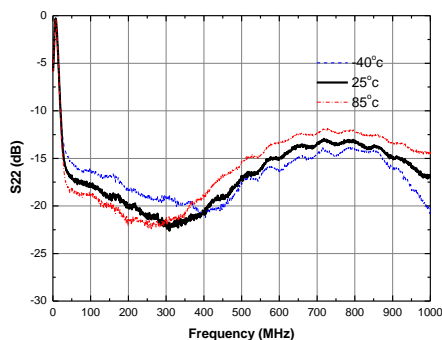
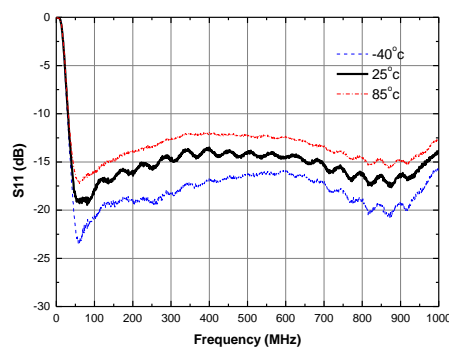
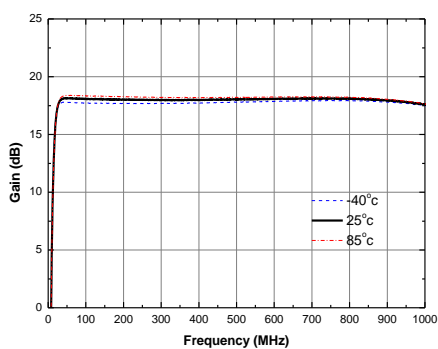

### Current vs. Temperature

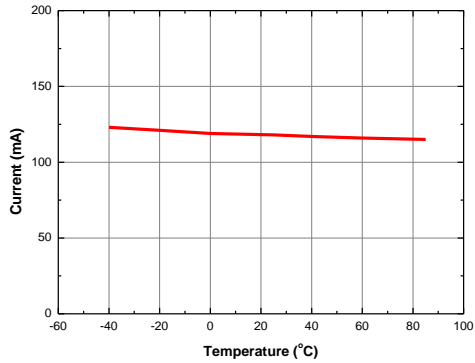

### Gain vs. Temperature

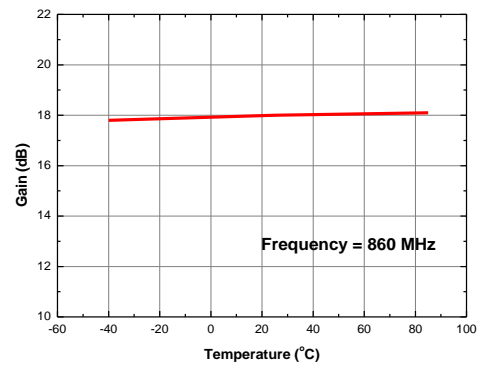

### P1dB vs. Temperature

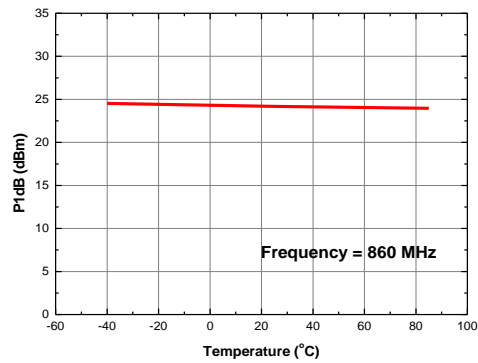

### NF vs. Temperature

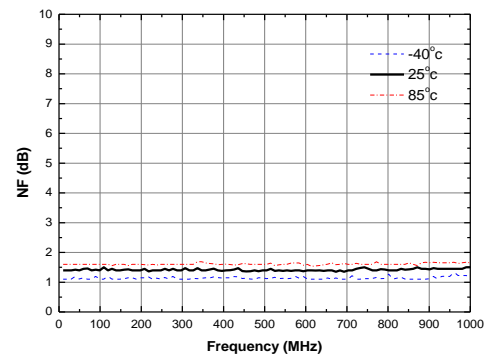

### Output IP3 vs. Tone Power (Frequency = 860 MHz)

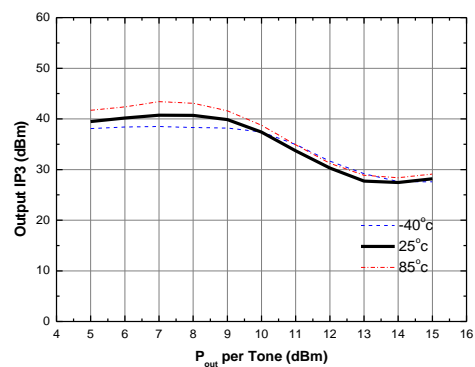

### Output IP2 vs. Tone Power (Frequency = 860 MHz)

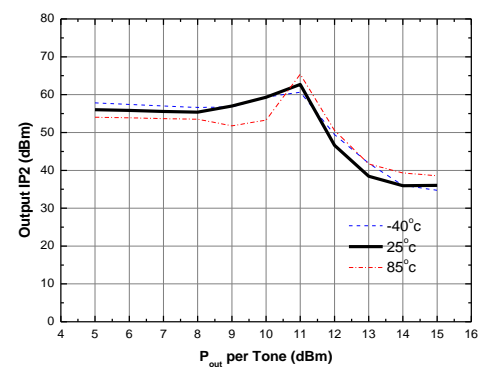

### APPLICATION CIRCUIT

CATV

50 ~ 1200 MHz

+8 V

Frequency (MHz)	50	500	1200
Noise Figure (dB)	1.7	1.7	1.9
Magnitude S21 (dB)	17.5	17.5	16.2
Magnitude S11 (dB)	-11	-12	-12
Magnitude S22 (dB)	-17	-17	-12
Output P1dB (dBm)	24.0	24.0	23.5
Output IP3 <sup>1)</sup> (dBm)	40.5	40.0	39.0
Output IP2 <sup>1,2)</sup> (dBm)	53	56	51
Device Voltage (V)	+8		
Current (mA)	120		

1) OIP3 and OIP2 are measured with two tones at an output power of +10 dBm/tone separated by 6 MHz.

2) OIP2 is measured at F1+F2 Frequency.

### Schematic

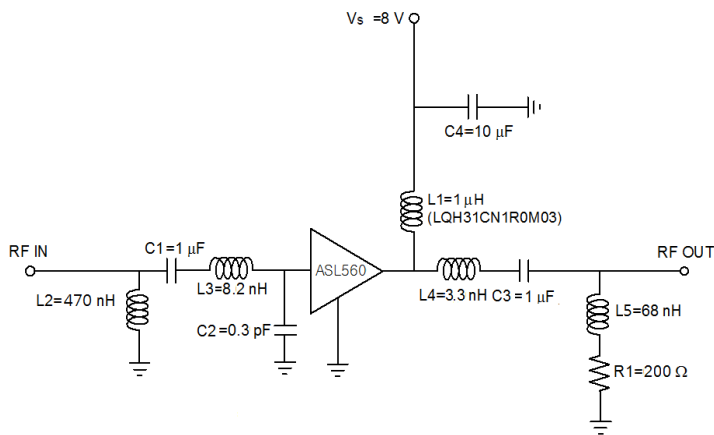

### Board Layout (FR4, 40x40 mm<sup>2</sup>, 0.8T)

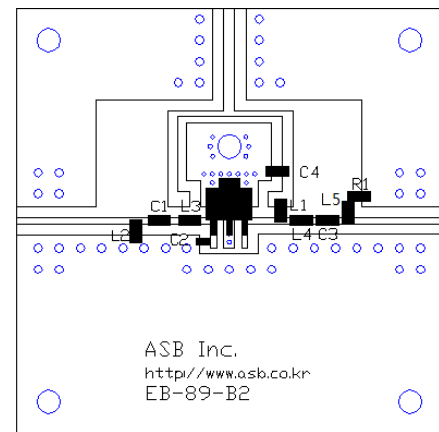

### S-parameters

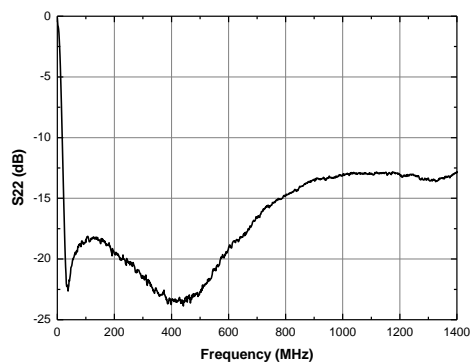
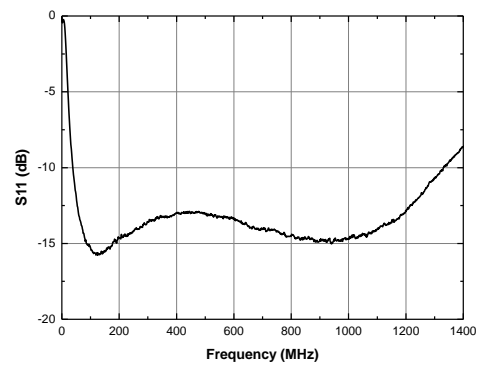
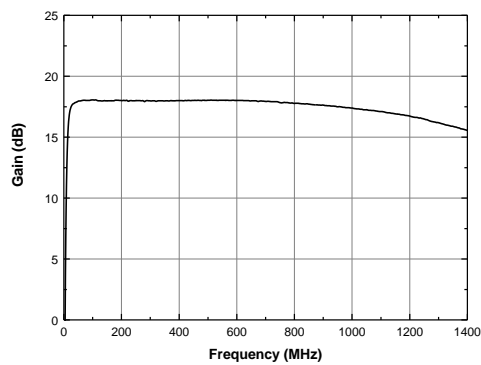

### APPLICATION CIRCUIT

CATV

5 ~ 200 MHz

+8 V

Frequency (MHz)	5	50	200
Noise Figure (dB)	2.1	1.5	1.5
Magnitude S21 (dB)	18.0	18.0	18.0
Magnitude S11 (dB)	-11	-20	-18
Magnitude S22 (dB)	-10	-20	-13
Output P1dB (dBm)	24	24	24
Output IP3 <sup>1)</sup> (dBm)	40	41	46
Output IP2 <sup>1),2)</sup> (dBm)	53	56	55
Device Voltage (V)	+8		
Current (mA)	120		

1) OIP3 and OIP2 are measured with two tones at an output power of +10 dBm/tone separated by 1 MHz.

2) OIP2 is measured at F1+F2 Frequency

### Schematic

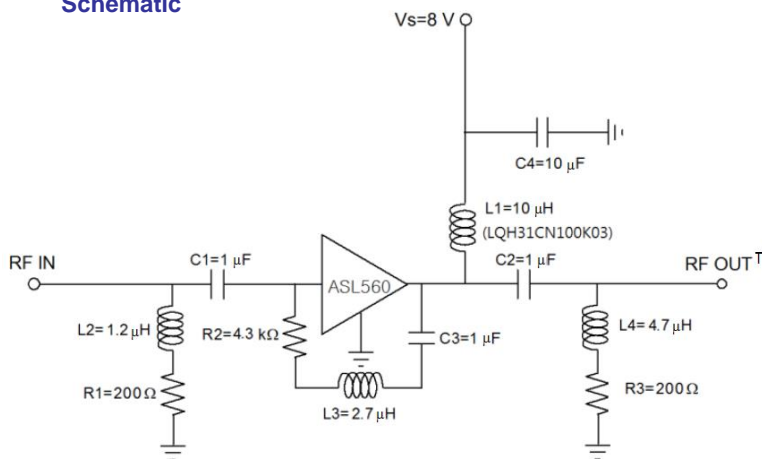

### Board Layout (FR4, 40x40 mm<sup>2</sup>, 0.8T)

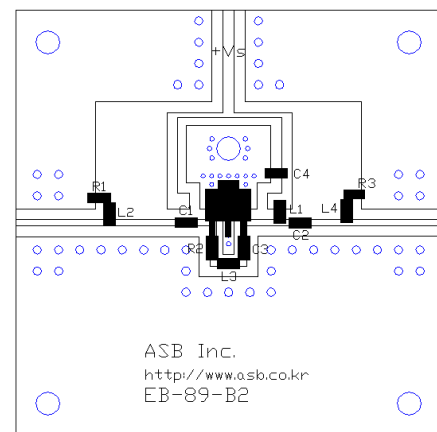

### S-parameters

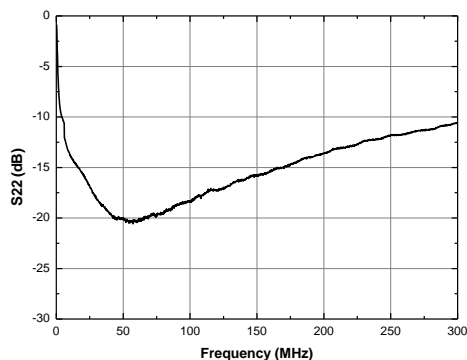
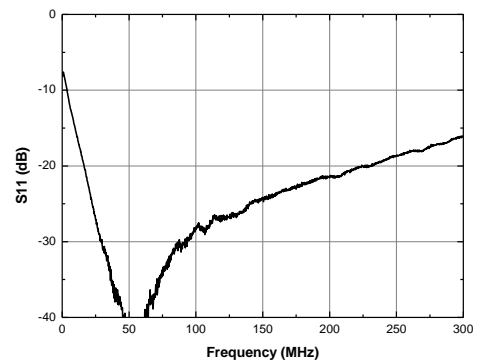
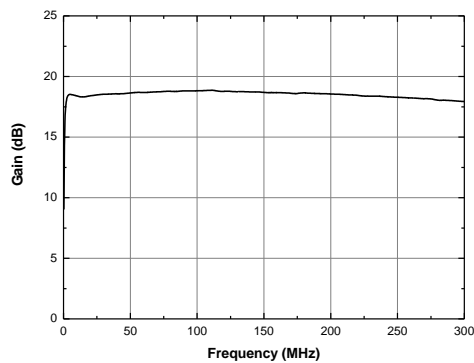

### APPLICATION CIRCUIT

**SMATV &  
Ethernet over Cable**

**950 ~ 1500 MHz**

**+8 V**

Frequency (MHz)	950	1200	1500
Noise Figure (dB)	1.9	2.0	2.0
Magnitude S21 (dB)	17.7	17.5	17.1
Magnitude S11 (dB)	-7	-7	-7
Magnitude S22 (dB)	-12	-17	-11
Output P1dB (dBm)	23.0	22.0	20.5
Output IP3 <sup>1)</sup> (dBm)	38	40	40
Output IP2 <sup>1),2)</sup> (dBm)	52	57	52
Device Voltage (V)	+8		
Current (mA)	120		

1) OIP3 and OIP2 are measured with two tones at an output power of +8 dBm/tone separated by 6 MHz.

2) OIP2 is measured at F1+F2 Frequency

### Schematic

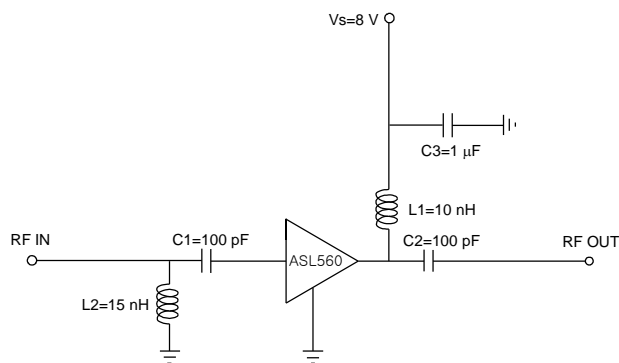

### Board Layout (FR4, 40x40 mm<sup>2</sup>, 0.8T)

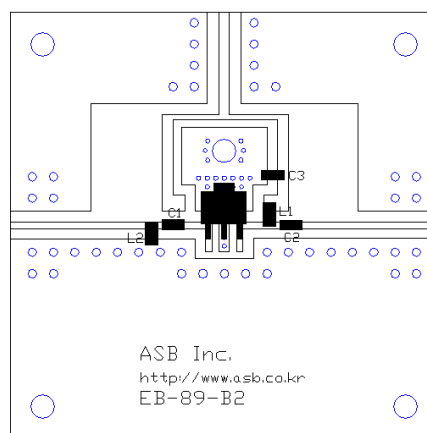

### S-parameters

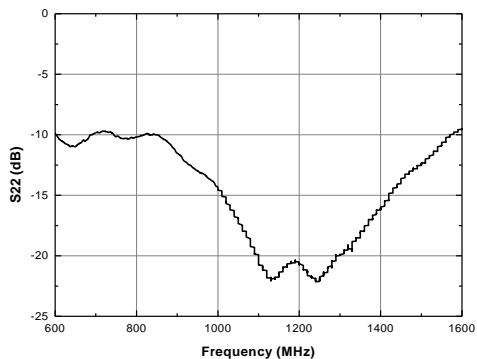
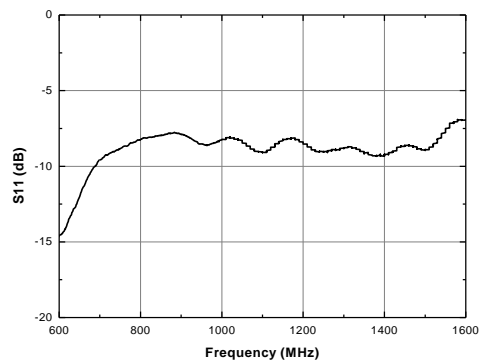
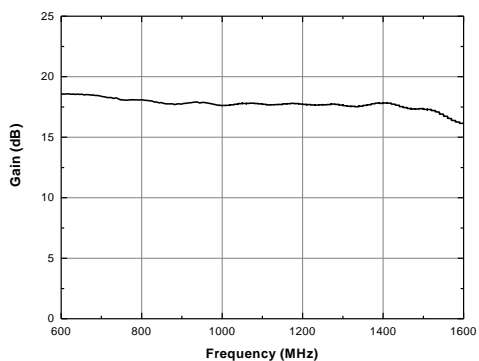

### APPLICATION CIRCUIT

SMATV

800 ~ 2500 MHz

+8 V

Frequency (MHz)	800	1500	2500
Noise Figure (dB)	2.3	3.0	2.5
Magnitude S21 (dB)	13.8	14.0	13.9
Magnitude S11 (dB)	-10	-11	-13
Magnitude S22 (dB)	-18	-13	-10
Output P1dB (dBm)	24	20	21
Output IP3 <sup>1)</sup> (dBm)	42.5	35.5	33.5
Output IP2 <sup>1),2)</sup> (dBm)	63	35	49
Device Voltage (V)	+8		
Current (mA)	120		

1) OIP3 and OIP2 are measured with two tones at an output power of +8 dBm/tone separated by 1 MHz.

2) OIP2 is measured at F1+F2 Frequency

### Schematic

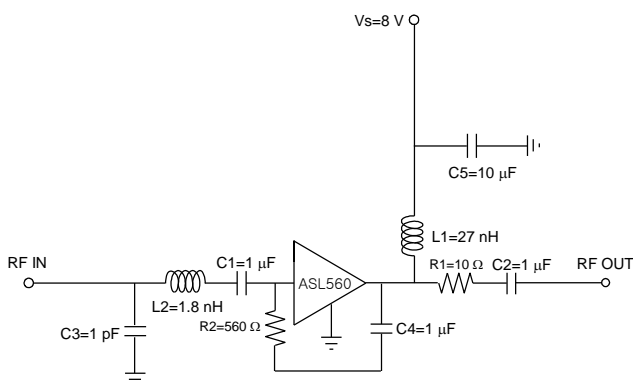

### Board Layout (FR4, 40x40 mm<sup>2</sup>, 0.8T)

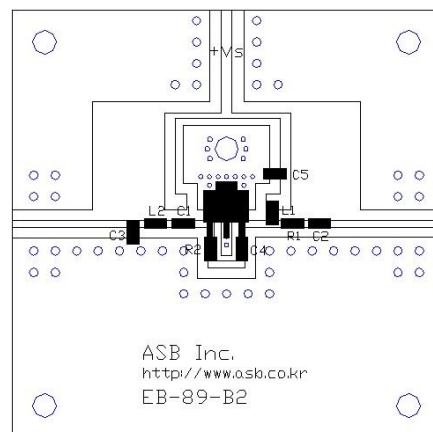

### S-parameters

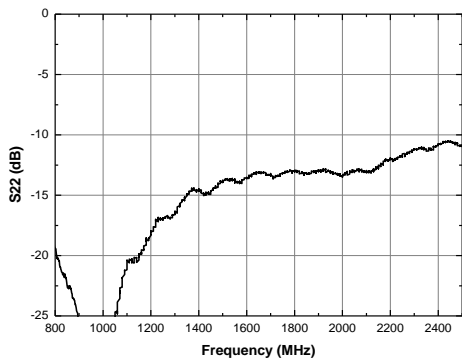
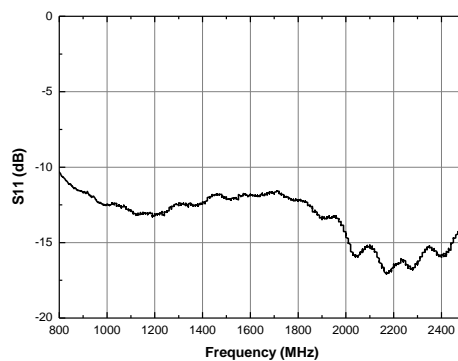
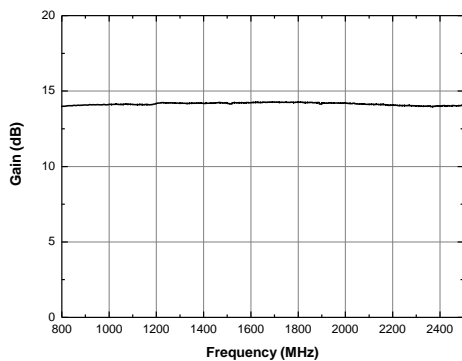



### APPLICATION CIRCUIT

CATV Push-Pull

1 : 1 transformer

50 ~ 1000 MHz

+8 V

Frequency (MHz)	50	500	860
Magnitude S21 (dB)	11.7	11.5	11.5
Magnitude S11 (dB)	-15	-11	-12
Magnitude S22 (dB)	-15	-12	-17
Output P1dB (dBm)	25	28	27
Output IP3 <sup>1)</sup> (dBm)	41.0	45.5	44.5
Output IP2 <sup>1),2)</sup> (dBm)	66	50	67
Noise Figure (dB)	2.9	2.8	2.7
Device Voltage (V)	+8		
Current (mA)	240		

1) OIP3 and OIP2 are measured with two tones at an output power of +10 dBm/tone separated by 6 MHz.

2) OIP2 is measured at F1+F2 Frequency.

### Schematic

Note: MABA-007159 1:1 impedance transformers are used.

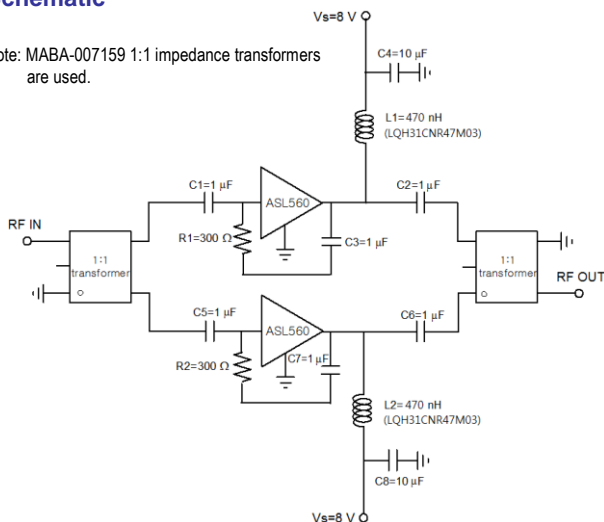

### Board Layout (FR4, 40x40 mm<sup>2</sup>, 0.8T)

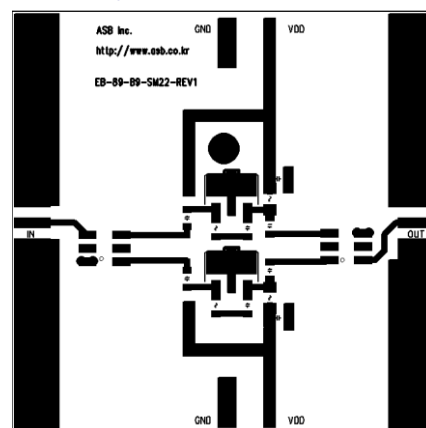

### S-parameters

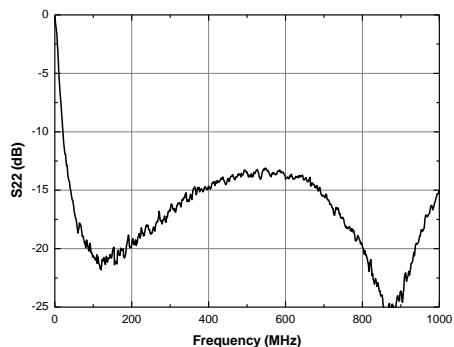
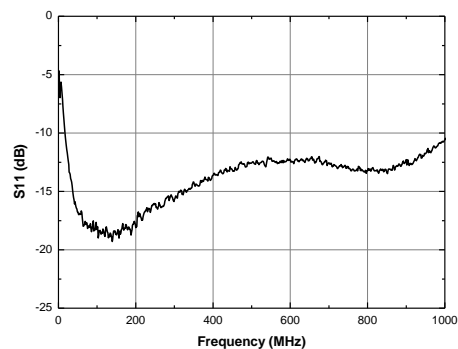
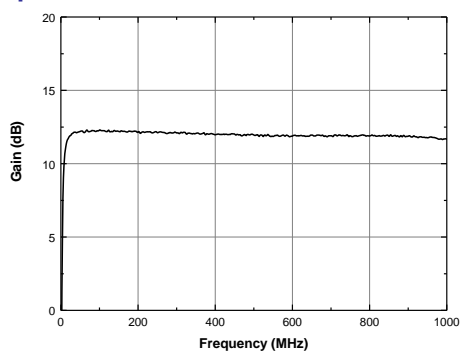

### APPLICATION CIRCUIT

CATV Push-Pull

1 : 1 transformer

50 ~ 1200 MHz

+8 V

Frequency (MHz)	50	500	1200
Magnitude S21 (dB)	11.7	11.3	11.4
Magnitude S11 (dB)	-15	-10	-10
Magnitude S22 (dB)	-15	-11	-10
Output P1dB (dBm)	25	28	27
Output IP3 <sup>1)</sup> (dBm)	41.0	45.5	44.5
Output IP2 <sup>1),2)</sup> (dBm)	68	68	57
Noise Figure (dB)	2.9	2.9	3.2
Device Voltage (V)	+8		
Current (mA)	240		

1) OIP3 and OIP2 are measured with two tones at an output power of +12 dBm/tone separated by 6 MHz.

2) OIP2 is measured at F1+F2 Frequency.

### Schematic

Note: MABA-007159 1:1 impedance transformers are used.

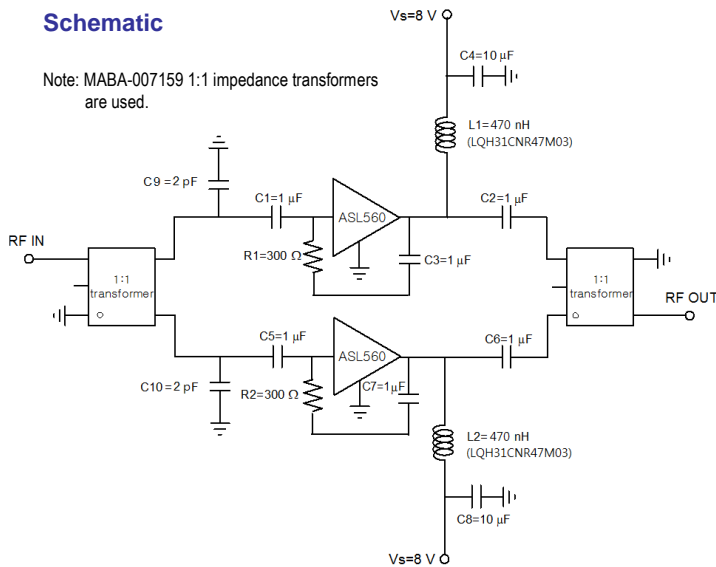

### Board Layout (FR4, 40x40 mm<sup>2</sup>, 0.8T)

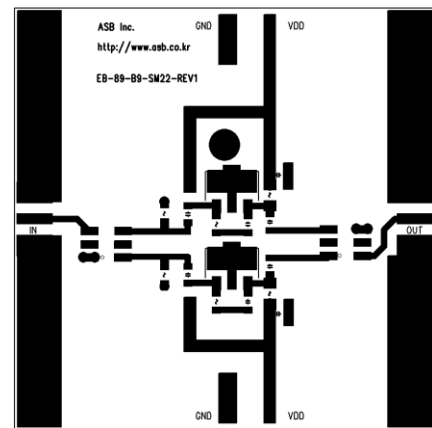

### S-parameters

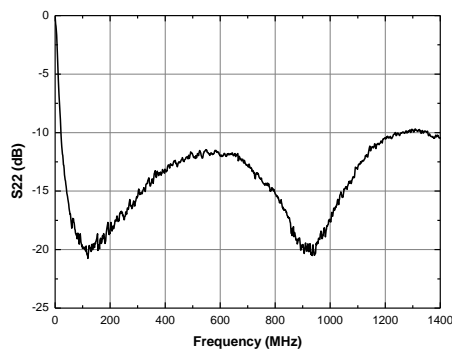
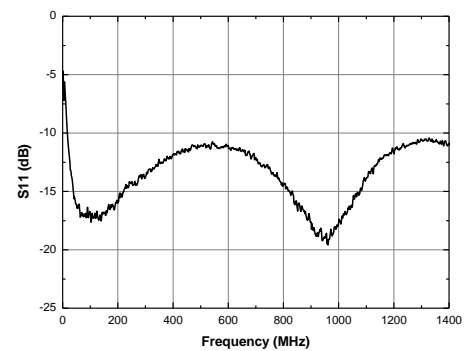
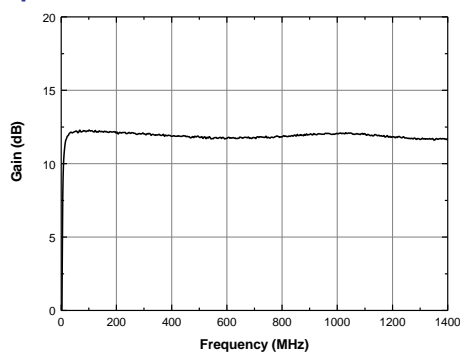

### APPLICATION CIRCUIT

CATV Push-Pull

1 : 1 transformer

5 ~ 200 MHz

+8 V

Frequency (MHz)	5	50	200
Magnitude S21 (dB)	12.0	12.0	11.8
Magnitude S11 (dB)	-17	-18	-17
Magnitude S22 (dB)	-17	-18	-17
Output P1dB (dBm)	25	26	26
Output IP3 <sup>1)</sup> (dBm)	39	42	45
Output IP2 <sup>1),2)</sup> (dBm)	62	67	73
Noise Figure (dB)	3.8	2.9	2.8
Device Voltage (V)	+8		
Current (mA)	240		

1) OIP3 and OIP2 are measured with two tones at an output power of +10 dBm/tone separated by 1 MHz.

2) OIP2 is measured at F1+F2 Frequency.

### Schematic

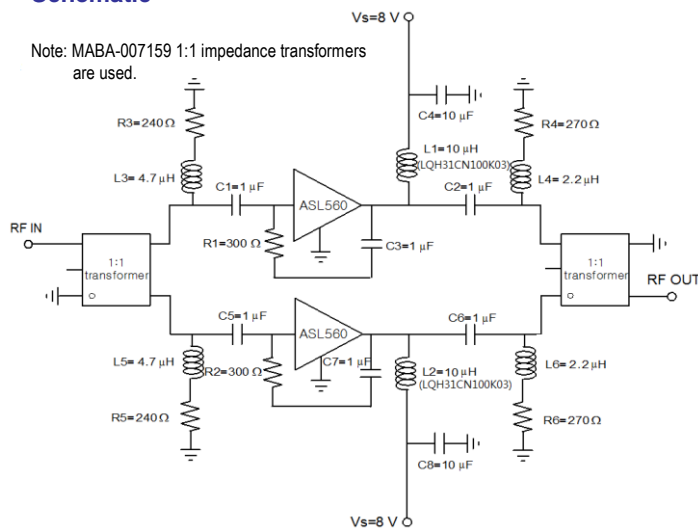

### Board Layout (FR4, 40x40 mm<sup>2</sup>, 0.8T)

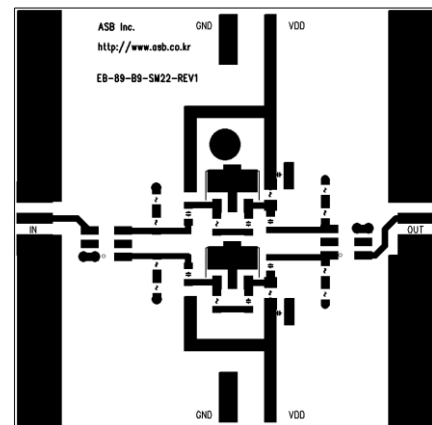

### S-parameters

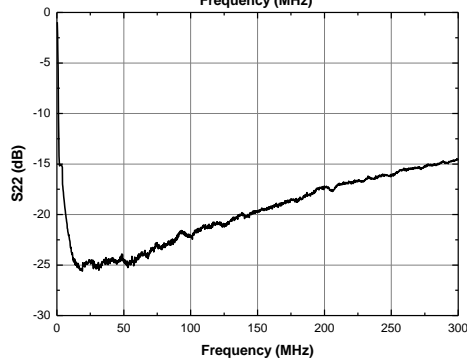
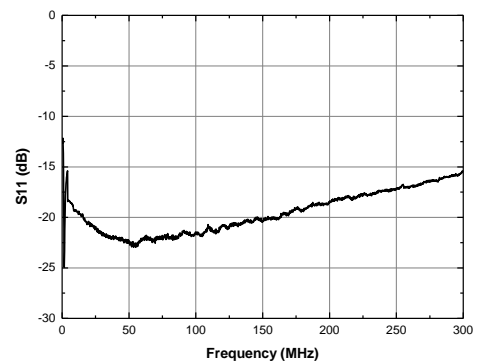
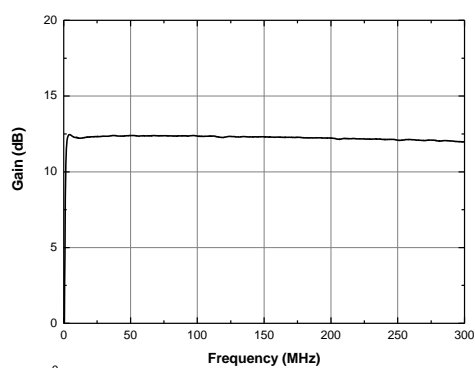

### Recommended Soldering Reflow Profile

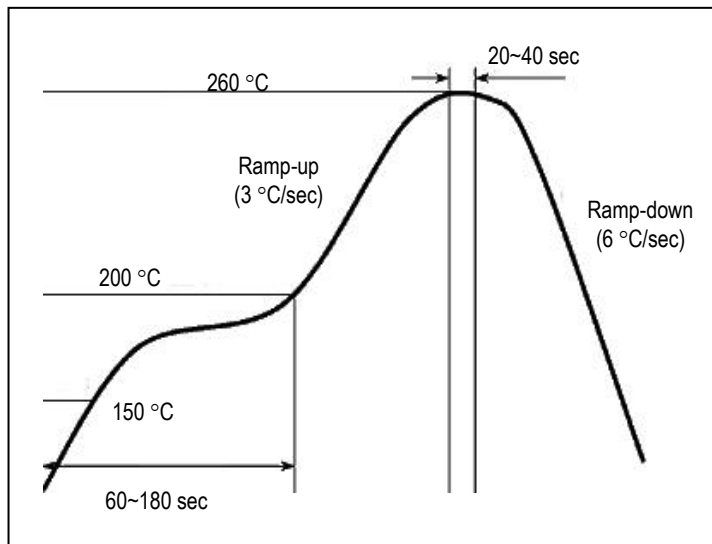

Copyright ©2010-2017 ASB Inc. All rights reserved. Datasheet subject to change without notice. ASB assumes no responsibility for any errors which may appear in this datasheet. No part of the datasheet may be copied or reproduced in any form or by any means without the prior written consent of ASB.