

AWG3020 Data Sheet

50 ~ 4000 MHz Wide-band Gain Block Amplifier MMIC

1. Product Overview

1.1 General Description

AWG3020, a gain block amplifier MMIC, has high linearity, low noise and high efficiency over a wide range of frequency from 30 MHz to 4000 MHz, being suitable for use in both receiver and transmitter of telecommunication system up to 4 GHz. It has an active bias network for stable current over temperature and process variation. The amplifier is available in an SOT89 package and passes through the stringent DC, RF, and reliability tests.

1.2 Features

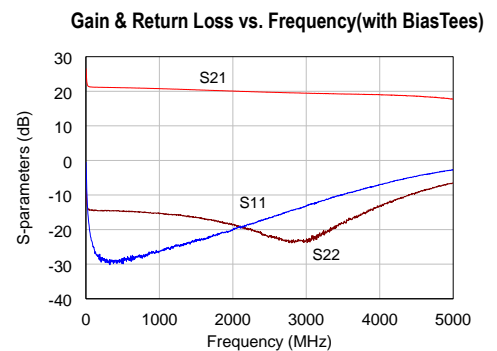

- 19.7 dB gain at 2000 MHz
- 20.0 dBm P1dB at 2000 MHz
- 39.0 dBm OIP3 at 2000 MHz
- Gain flatness = 1.4 dB at 500 ~ 2500 MHz
- 50 Ω input & output matching
- MTTF > 100 Years
- Single supply: +5 V



1.3 Applications

- Wide-band application at 100 ~ 3500 MHz
- IF, CATV application at 30 ~ 1200 MHz
- SMATV, ONU application at 50 ~ 3000 MHz

1.4 Package Profile & RoHS Compliance

| | |
|---|--|
|  <p>SOT89, 4.5x4.0 mm², surface mount</p> |  <p>RoHS-compliant</p> |
|---|--|

2. Summary on Product Performances

2.1 Typical Performance

Supply voltage = +5 V, T_A = +25 °C, Z_O = 50 Ω.

| Parameter | Typical | | | | | | | | Unit |
|--------------------------|---------|-------|-------|-------|-------|-------|-------|-------|------|
| Frequency | 70 | 150 | 450 | 900 | 2000 | 2500 | 3000 | 3500 | MHz |
| Gain | 21.2 | 21.1 | 20.9 | 20.6 | 19.7 | 19.3 | 19.0 | 19.0 | dB |
| S11 | -18.0 | -20.0 | -20.0 | -18.0 | -20.0 | -20.0 | -17.0 | -13.0 | dB |
| S22 | -14.0 | -14.0 | -15.0 | -13.0 | -15.0 | -15.0 | -17.0 | -17.0 | dB |
| Noise Figure | 1.7 | 1.7 | 1.7 | 1.6 | 2.1 | 2.4 | 2.8 | 3.2 | dB |
| Output IP3 ¹⁾ | 38.0 | 38.0 | 39.0 | 39.0 | 39.0 | 39.0 | 32.0 | 27.0 | dBm |
| Output P1dB | 20.0 | 20.0 | 20.0 | 20.0 | 20.0 | 19.5 | 18.0 | 16.0 | dBm |
| Current | 104 | | | | | | | | mA |
| Device Voltage | +3.9 | | | | | | | | V |

1) OIP3 is measured with two tones at an output power of +5 dBm/tone separated by 1MHz.

2.2 Product Specification

Supply voltage = +5 V, T_A = +25 °C, Z_O = 50 Ω.

| Parameter | Min | Typ | Max | Unit |
|----------------|-----|-------|-----|------|
| Frequency | | 2000 | | MHz |
| Gain | | 19.7 | | dB |
| S11 | | -20.0 | | dB |
| S22 | | -15.0 | | dB |
| Noise Figure | | 2.1 | | dB |
| OIP3 | | 39.0 | | dBm |
| P1dB | | 20.0 | | dBm |
| Current | | 104 | | mA |
| Device Voltage | | +3.9 | | V |

2.3 Pin Configuration

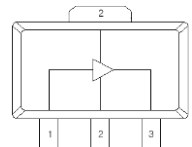
| Pin | Description | Simplified Outline |
|-----|---------------|---|
| 1 | RF_IN |  |
| 2 | Ground | |
| 3 | RF_OUT & Bias | |

2.4 Absolute Maximum Ratings

| Parameters | Max. Ratings |
|---|----------------|
| Operation Case Temperature | -40 to +85 °C |
| Storage Temperature | -40 to +150 °C |
| Device Voltage | +6 V |
| Operation Junction Temperature | +150 °C |
| Input RF Power (At 2000 MHz, CW, 50 Ω matched)* | + 27 dBm |

The operation of this device in excess of any of these limits may cause permanent damage.

* Refer to the max. input RF power data at http://www.asb.co.kr/pdf/Maximum_Input_Power_Analysis.pdf. The max. input RF power, in principle, depends upon application frequency, matching circuit, and device voltage.

2.5 Thermal Resistance

| Symbol | Description | Typ | Unit |
|-----------------|--|-----|------|
| R _{th} | Thermal resistance from junction to lead | 55 | °C/W |

2.6 ESD Classification & Moisture Sensitivity Level

ESD Classification

| | | |
|-------------------------------|----------|--|
| HBM | Class 1B | Voltage Level: 750 V |
| MM | Class A | Voltage Level: 100 V |
| Contact Discharge | | Voltage Level: 1.8 kV (Input), 4 kV (Output) |
| Air Contact Discharge (10 cm) | | Voltage Level: > 20 kV |

CAUTION: Gallium Arsenide Integrated Circuits are sensitive to electrostatic discharge (ESD) and can be damaged by static electricity. Proper ESD control techniques should be used when handling these devices.

Moisture Sensitivity Level

| |
|------------------------|
| MSL 3 at 260 °C reflow |
|------------------------|

(Intentionally Blanked)

3. Application: 500 ~ 3000 MHz

3.1 Application Circuit & Evaluation Board

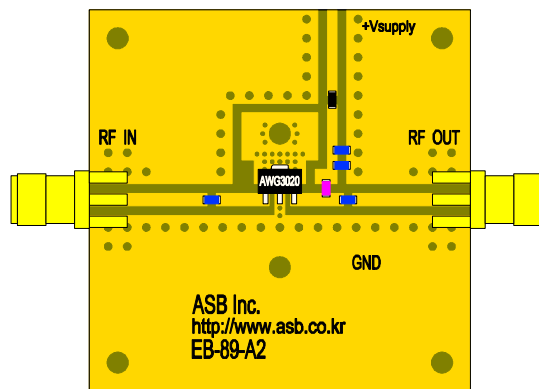
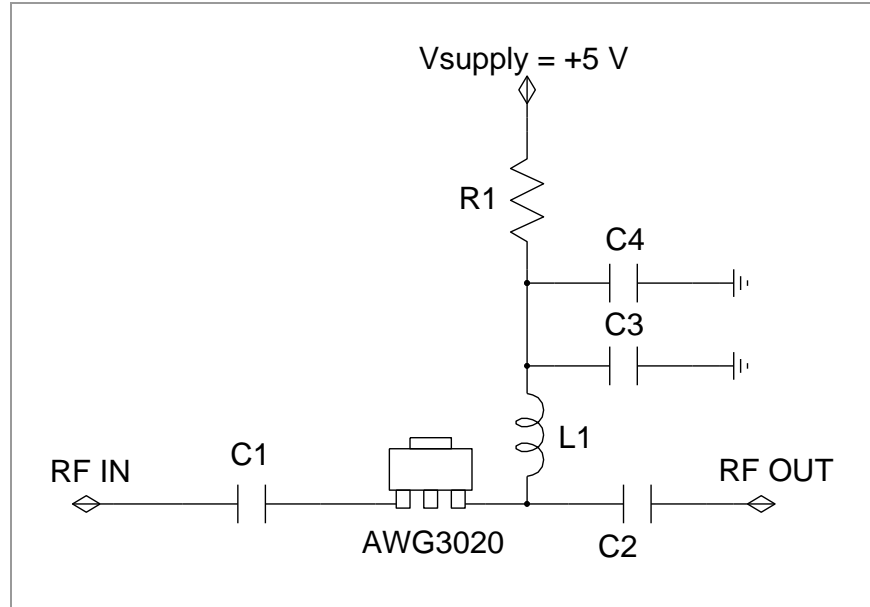

| PCB Information | |
|-----------------|----------|
| Material | FR4 |
| Thickness (mm) | 0.8 |
| Size (mm) | 40x40 |
| EB No. | EB-89-A2 |

Bill of Material

| Symbol | Value | Size | Description | Manufacturer |
|---------|-------------|------|-----------------------|--------------|
| AWG3020 | - | - | MMIC Amplifier | ASB |
| C1, C2 | 100 pF | 0603 | DC blocking capacitor | Murata |
| C3 | 100 pF | 0603 | Decoupling capacitor | Murata |
| C4 | 1 μ F | 0603 | Decoupling capacitor | Murata |
| L1 | 33 nH | 0603 | RF choke inductor | Murata |
| R1 | 10 Ω | 0603 | Drop resistor | Samsung |

3.2 Performance Table

Supply voltage = +5 V, T_A = +25 °C, Z₀ = 50 Ω.

| Parameter | Typical | | | | | | Unit |
|--------------------------|---------|-------|-------|-------|-------|-------|------|
| Frequency | 500 | 900 | 2000 | 2500 | 2700 | 3000 | MHz |
| Gain | 20.7 | 20.6 | 19.7 | 19.3 | 19.1 | 19.0 | dB |
| S11 | -14.0 | -18.0 | -20.0 | -20.0 | -18.0 | -15.0 | dB |
| S22 | -11.0 | -13.0 | -15.0 | -15.0 | -16.0 | -18.0 | dB |
| Noise Figure | 1.6 | 1.6 | 2.1 | 2.4 | 2.7 | 3.1 | dB |
| Output IP3 ¹⁾ | 40.0 | 39.0 | 39.0 | 39.0 | 34.0 | 30.0 | dBm |
| Output P1dB | 20.0 | 20.0 | 20.0 | 19.5 | 19.5 | 18.0 | dBm |
| Current | 104 | | | | | | mA |
| Device Voltage | +3.9 | | | | | | V |

1) OIP3 is measured with two tones at an output power of +5 dBm/tone separated by 1MHz.

3.3 Plot of S-parameter & Stability Factor

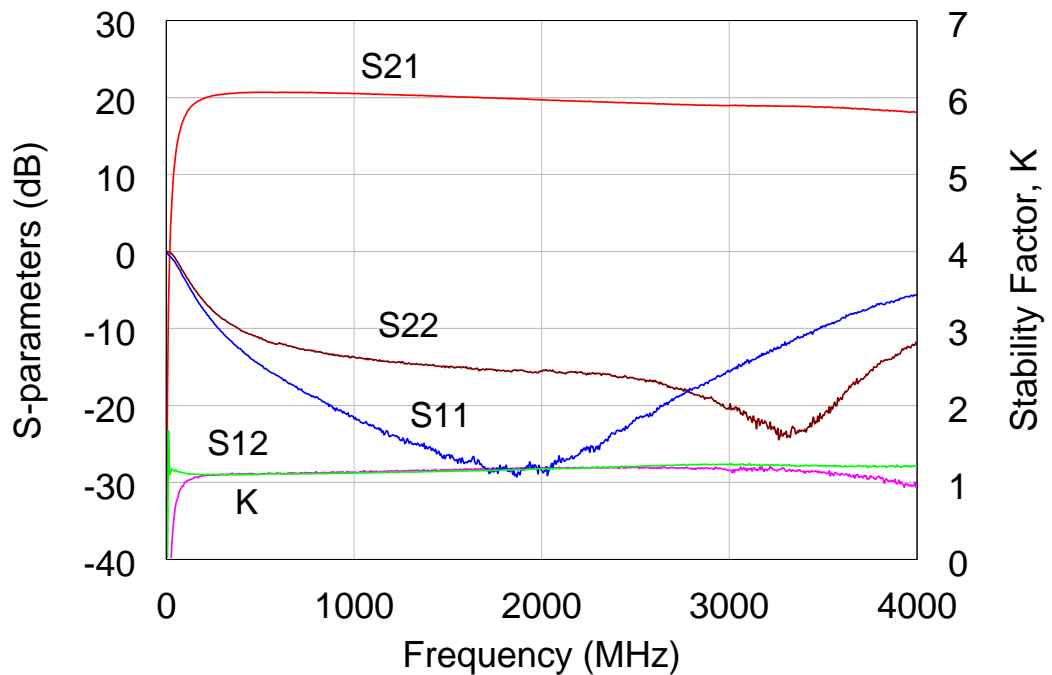

3.4 Plots of Noise Figure and Performances with Temperature

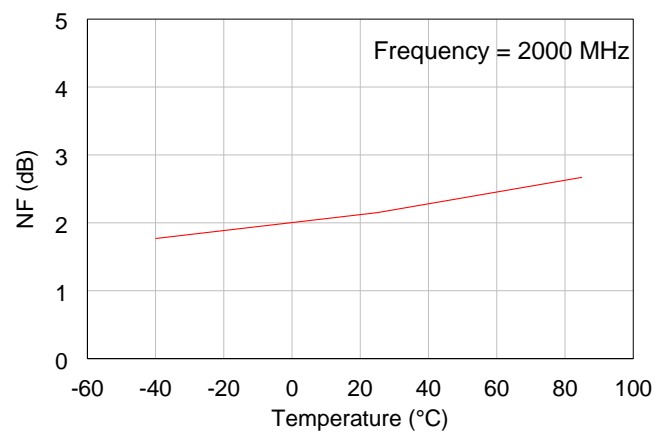
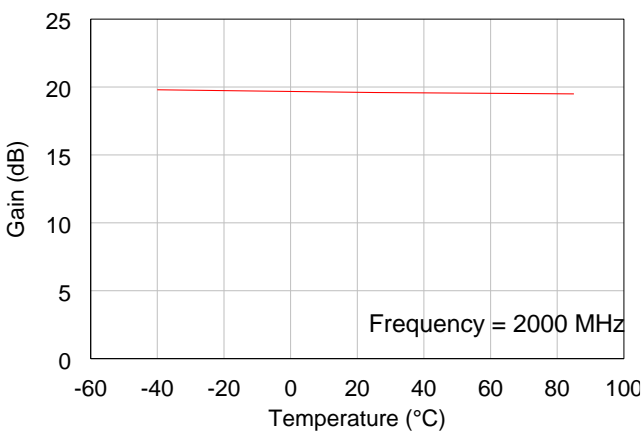
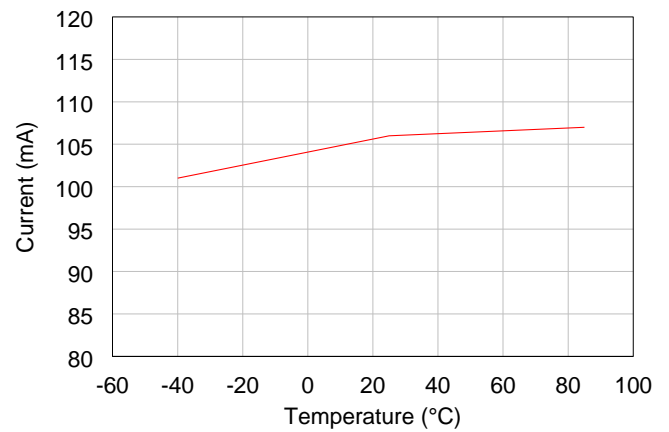
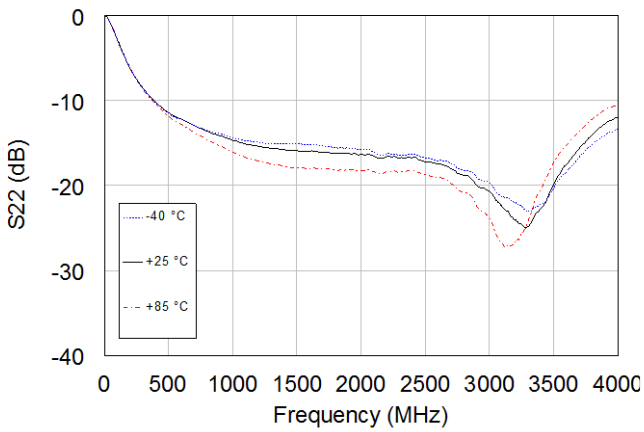
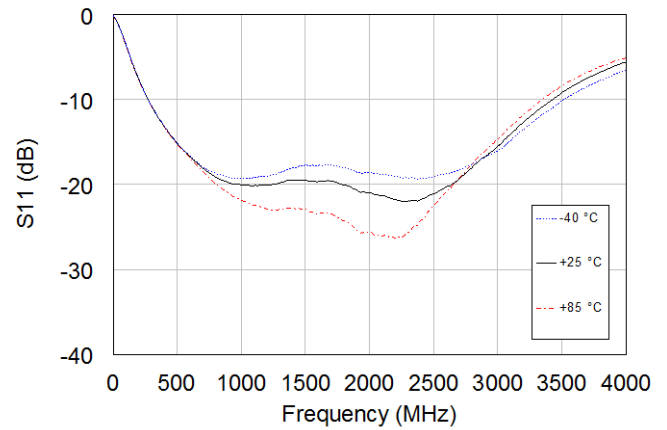
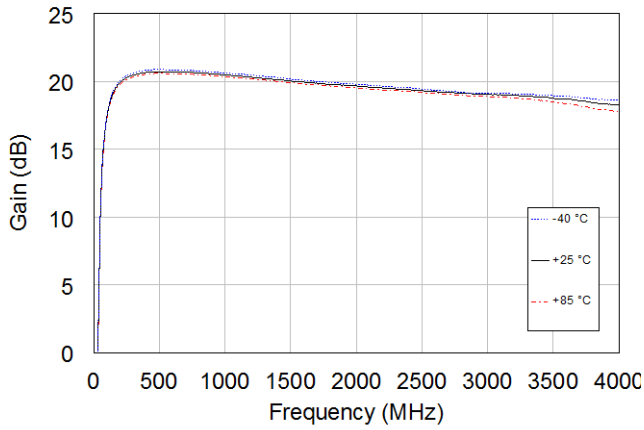

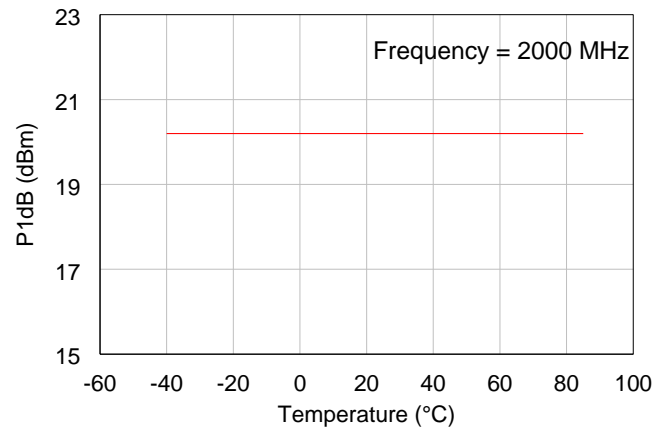
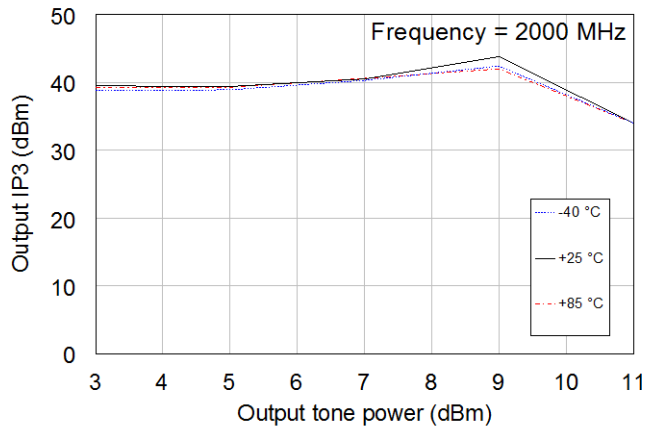

4. Application: 30 ~ 1200 MHz (IF, CATV)

4.1 Application Circuit & Evaluation Board

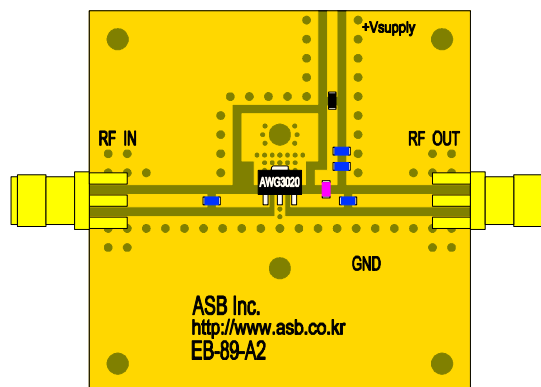
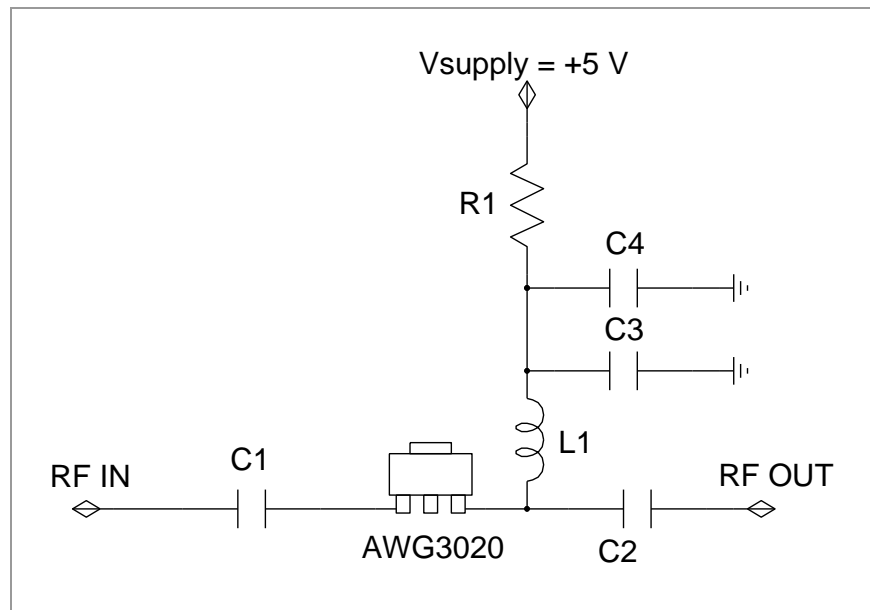

| PCB Information | |
|-----------------|----------|
| Material | FR4 |
| Thickness (mm) | 0.8 |
| Size (mm) | 40x40 |
| EB No. | EB-89-A2 |

Bill of Material

| Symbol | Value | Size | Description | Manufacturer |
|---------|-------------|------|-----------------------|--------------|
| AWG3020 | - | - | MMIC Amplifier | ASB |
| C1, C2 | 1 μ F | 0603 | DC blocking capacitor | Murata |
| C3 | - | - | Not used | |
| C4 | 10 μ F | 0805 | Decoupling capacitor | Murata |
| L1 | 3.3 μ H | 0603 | RF choke inductor | Samsung |
| R1 | 10 Ω | 0603 | Drop resistor | Samsung |

4.2 Performance Table

Supply voltage = +5 V, T_A = +25 °C, Z_O = 50 Ω.

| Parameter | Typical | | | | | | | | Unit |
|--------------------------|---------|-------|-------|-------|-------|-------|-------|-------|------|
| Frequency | 30 | 70 | 150 | 300 | 450 | 860 | 1000 | 1200 | MHz |
| Gain | 21.5 | 21.2 | 21.1 | 21.0 | 20.9 | 20.6 | 20.5 | 20.3 | dB |
| S11 | -12.0 | -18.0 | -20.0 | -20.0 | -20.0 | -18.0 | -17.0 | -15.0 | dB |
| S22 | -15.0 | -14.0 | -14.0 | -14.0 | -15.0 | -16.0 | -17.0 | -18.0 | dB |
| Noise Figure | 1.8 | 1.7 | 1.7 | 1.7 | 1.7 | 1.7 | 1.7 | 1.7 | dB |
| Output IP3 ¹⁾ | 37.0 | 38.0 | 38.0 | 39.0 | 39.0 | 38.0 | 38.0 | 37.5 | dBm |
| Output P1dB | 20.0 | 20.0 | 20.0 | 20.0 | 20.0 | 20.0 | 20.0 | 20.0 | dBm |
| Current | 104 | | | | | | | | mA |
| Device Voltage | +3.9 | | | | | | | | V |

1) OIP3 is measured with two tones at an output power of +5 dBm/tone separated by 1MHz.

4.3 Plot of S-parameter & Stability Factor

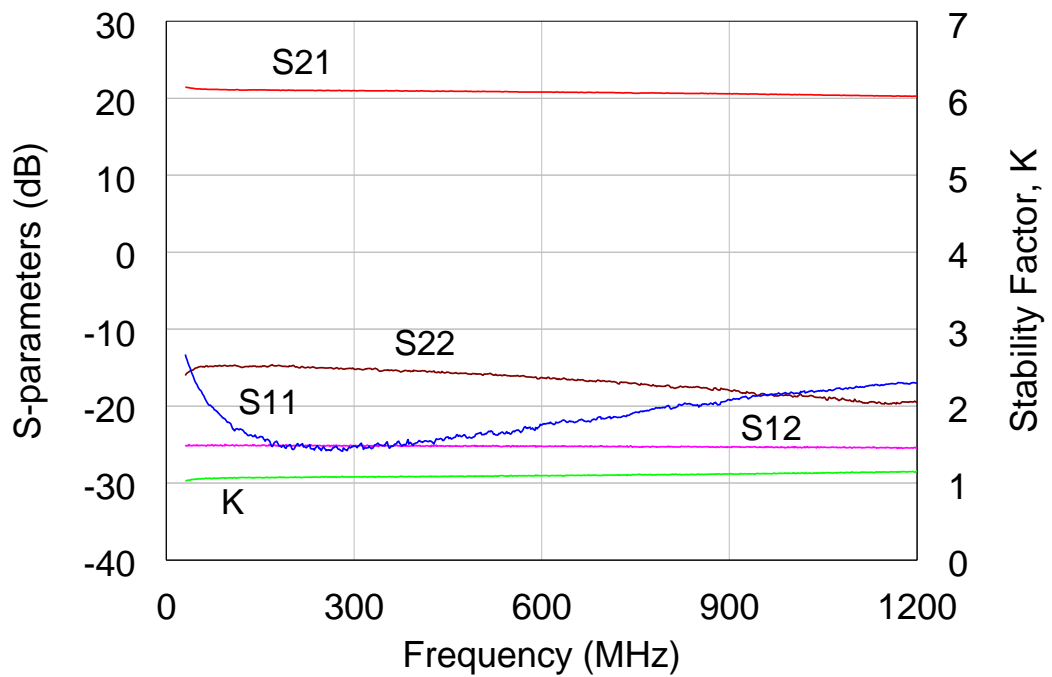

5. Application: 50 ~ 3000 MHz (SMATV, ONU)

5.1 Application Circuit & Evaluation Board

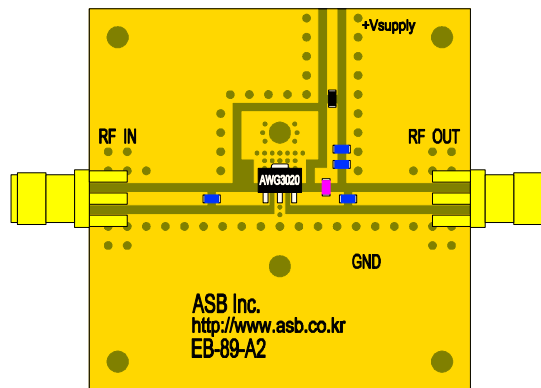
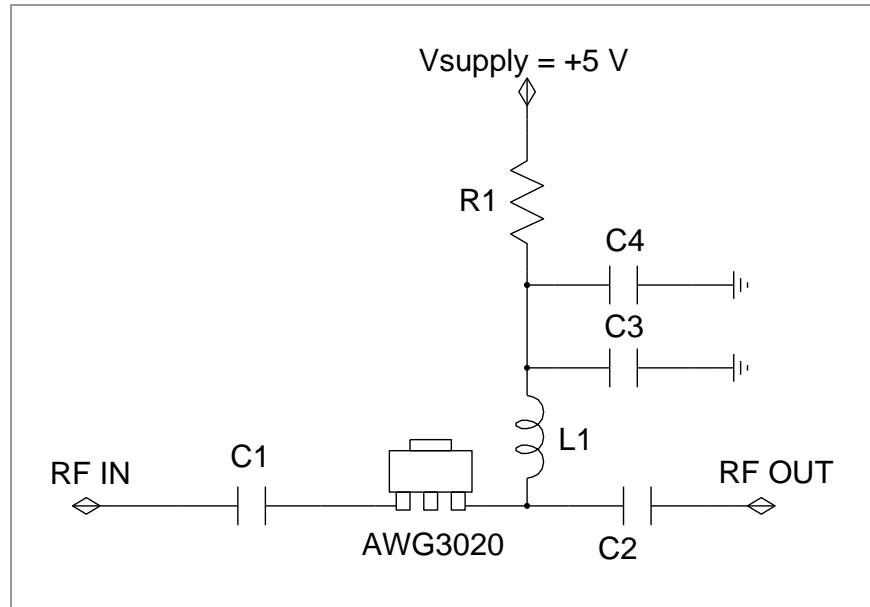

| PCB Information | |
|-----------------|----------|
| Material | FR4 |
| Thickness (mm) | 0.8 |
| Size (mm) | 40x40 |
| EB No. | EB-89-A2 |

Bill of Material

| Symbol | Value | Size | Description | Manufacturer |
|---------|-------------|------|-----------------------|--------------|
| AWG3020 | - | - | MMIC Amplifier | ASB |
| C1, C2 | 1 μ F | 0603 | DC blocking capacitor | Murata |
| C3 | - | - | Not used | |
| C4 | 10 μ F | 0805 | Decoupling capacitor | Murata |
| L1 | 1 μ H | 0603 | RF choke inductor | Samsung |
| R1 | 10 Ω | 0603 | Drop resistor | Samsung |

5.2 Performance Table

Supply voltage = +5 V, T_A = +25 °C, Z₀ = 50 Ω.

| Parameter | Typical | | | | | | Unit |
|--------------------------|---------|-------|-------|-------|-------|-------|------|
| Frequency | 50 | 500 | 1000 | 2000 | 2500 | 3000 | MHz |
| Gain | 20.9 | 20.7 | 20.3 | 18.8 | 18.1 | 17.2 | dB |
| S11 | -13.0 | -20.0 | -17.0 | -14.0 | -14.0 | -13.0 | dB |
| S22 | -16.0 | -16.0 | -17.0 | -16.0 | -16.0 | -14.0 | dB |
| Noise Figure | 2.0 | 1.7 | 1.7 | 2.0 | 2.5 | 3.0 | dB |
| Output IP3 ¹⁾ | 36.0 | 40.0 | 38.0 | 37.0 | 37.0 | 31.0 | dBm |
| Output P1dB | 20.0 | 20.0 | 20.0 | 20.0 | 19.0 | 17.0 | dBm |
| Current | 104 | | | | | | mA |
| Device Voltage | +3.9 | | | | | | V |

1) OIP3 is measured with two tones at an output power of +5 dBm/tone separated by 1MHz.

5.3 Plot of S-parameter & Stability Factor

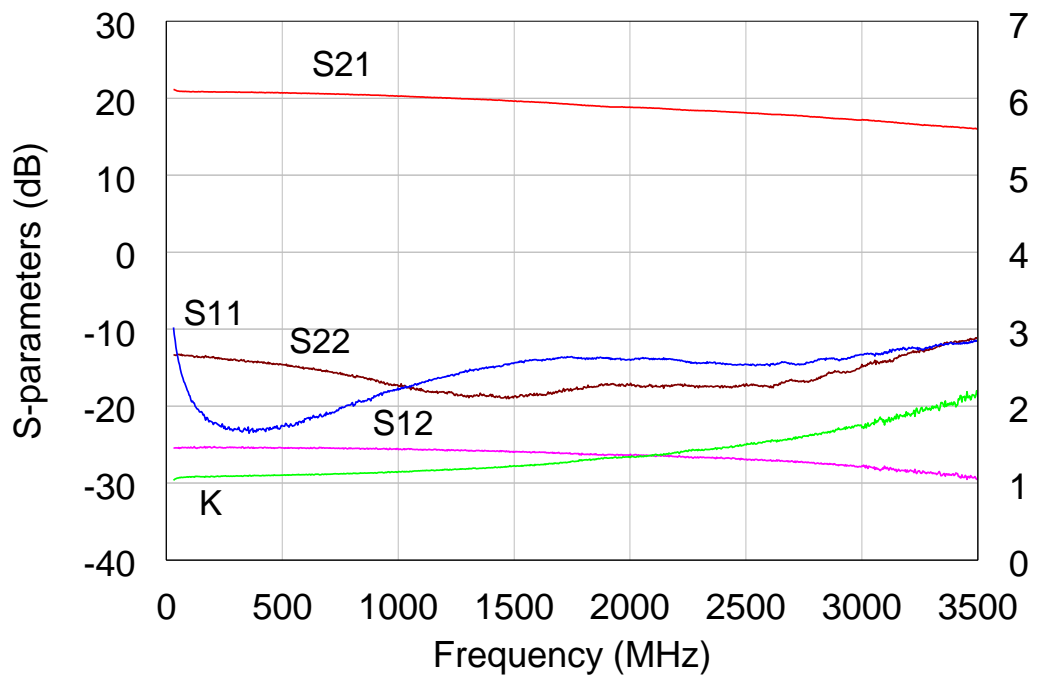

6. Application: 100 ~ 3500 MHz

6.1 Application Circuit & Evaluation Board

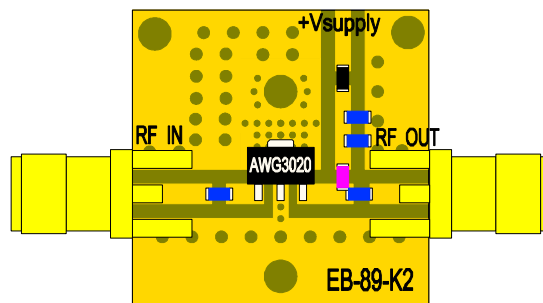
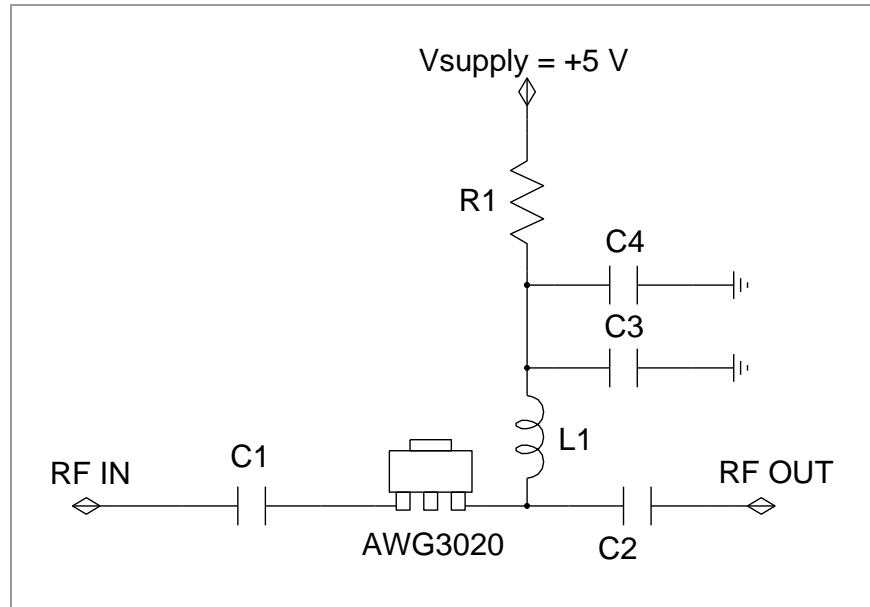

| PCB Information | |
|-----------------|----------|
| Material | FR4 |
| Thickness (mm) | 0.8 |
| Size (mm) | 25x25 |
| EB No. | EB-89-K2 |

Bill of Material

| Symbol | Value | Size | Description | Manufacturer |
|---------|-------------|------|--------------------------|--------------|
| AWG3020 | - | - | MMIC Amplifier | ASB |
| C1, C2 | 100 pF | 0603 | DC blocking capacitor | Murata |
| C3 | - | - | Not used | |
| C4 | 1 μ F | 0805 | Decoupling capacitor | Murata |
| L1 | 150 nH | 0603 | RF choke inductor (Coil) | Murata |
| R1 | 10 Ω | 0603 | Drop resistor | Samsung |

6.2 Performance Table

Supply voltage = +5 V, $T_A = +25\text{ }^\circ\text{C}$, $Z_0 = 50\ \Omega$.

| Parameter | Typical | | | | | | | Unit |
|--------------------------|---------|-------|-------|-------|-------|-------|-------|------|
| Frequency | 100 | 500 | 900 | 2000 | 2500 | 3000 | 3500 | MHz |
| Gain | 20.7 | 21.0 | 20.7 | 19.9 | 19.4 | 19.0 | 19.0 | dB |
| S11 | -10.0 | -18.0 | -20.0 | -20.0 | -20.0 | -17.0 | -13.0 | dB |
| S22 | -10.0 | -13.0 | -14.0 | -14.0 | -15.0 | -17.0 | -17.0 | dB |
| Noise Figure | 2.0 | 1.7 | 1.7 | 2.0 | 2.4 | 2.8 | 3.2 | dB |
| Output IP3 ¹⁾ | 38.0 | 39.0 | 38.0 | 38.0 | 36.0 | 32.0 | 27.0 | dBm |
| Output P1dB | 19.0 | 20.0 | 20.0 | 19.5 | 19.0 | 18.0 | 16.0 | dBm |
| Current | 104 | | | | | | | mA |
| Device Voltage | +3.9 | | | | | | | V |

1) OIP3 is measured with two tones at an output power of +5 dBm/tone separated by 1MHz.

6.3 Plot of S-parameter & Stability Factor

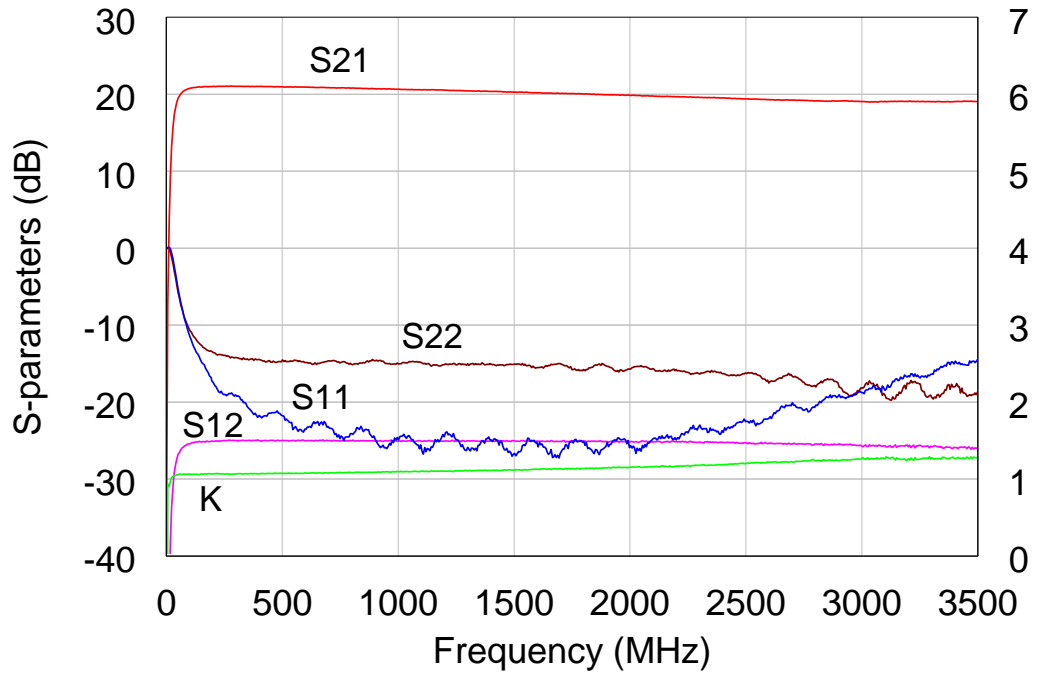

7. Package Outline (SOT89, 4.5x4.0x1.5 mm)

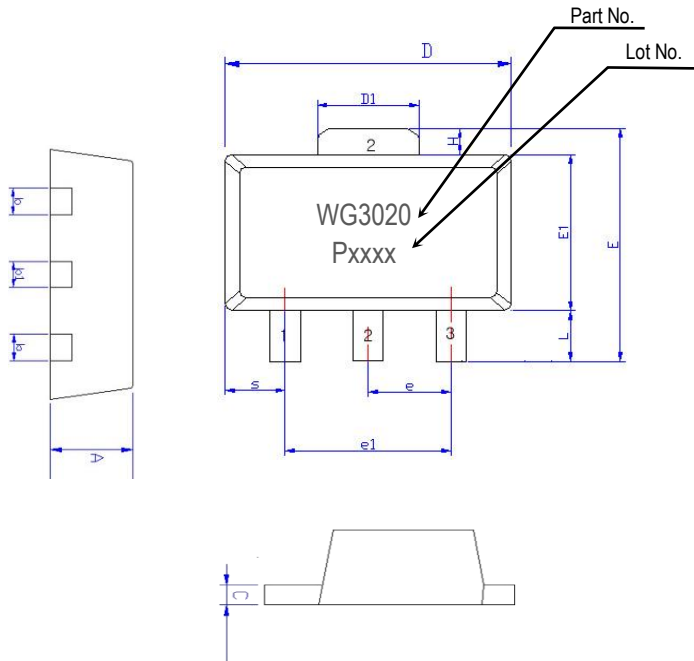

| Symbols | Dimensions (In mm) | | |
|---------|--------------------|------|------|
| | MIN | NOM | MAX |
| A | 1.40 | 1.50 | 1.60 |
| L | 0.89 | 1.04 | 1.20 |
| b | 0.36 | 0.42 | 0.48 |
| b1 | 0.41 | 0.47 | 0.53 |
| C | 0.38 | 0.40 | 0.43 |
| D | 4.40 | 4.50 | 4.60 |
| D1 | 1.40 | 1.60 | 1.75 |
| E | 3.64 | --- | 4.25 |
| E1 | 2.40 | 2.50 | 2.60 |
| e1 | 2.90 | 3.00 | 3.10 |
| H | 0.35 | 0.40 | 0.45 |
| S | 0.65 | 0.75 | 0.85 |
| e | 1.40 | 1.50 | 1.60 |

8. Surface Mount Recommendation (In mm)

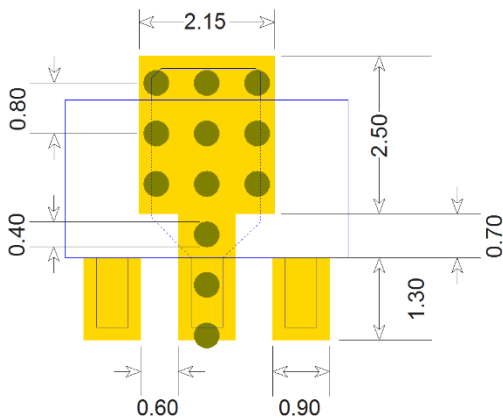

NOTE

1. The number and size of ground via holes in a circuit board are critical for thermal and RF grounding considerations.
2. We recommend that the ground via holes be placed on the bottom of the lead pin 2 and exposed pad of the device for better RF and thermal performance, as shown in the drawing at the left side.

9. Recommended Soldering Reflow Profile

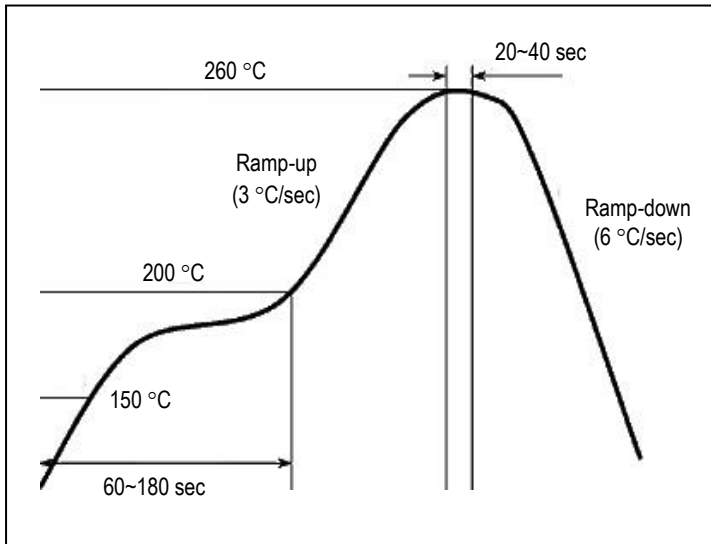

(End of Datasheet)

Copyright ©2014-2017 ASB Inc. All rights reserved. Datasheet subject to change without notice. ASB assumes no responsibility for any errors which may appear in this datasheet. No part of the datasheet may be copied or reproduced in any form or by any means without the prior written consent of ASB.